

# CLEANING, POLISHING, and FRESHENING

## Kitchen Cleaning

### Dishwasher

■ A heavy film buildup from hard water minerals can be removed by adding vinegar to an empty dishwasher after it fills with water at the start of its first cycle. Do this only if the appliance manual suggests this is OK, and if the buildup bothers you (as it does no harm).

### Freezer

■ Turn off and unplug freezer. Remove food and let freezer defrost. Wash inside with warm water solution of mild detergent or baking soda (2 tablespoons per quart of warm water). Rinse; wipe as dry as possible. Vacuum dust off condenser coils. Turn freezer back on and restock.

### Garbage Disposal

■ If you plan to leave home for several days, check to be sure all wastes have been flushed out of the disposal to avoid coming home to garbage odors. If odors occur, they can be removed by running orange or lemon peels or ice cubes through the disposal.

### Oven and Stove

■ To prevent messy oven cleanups, put a sheet of aluminum foil on the floor of the oven, but do not allow the foil to touch the heating element. Although this may slightly affect the browning of food, the foil can be easily disposed of when soiled.

- Clean up any spill as soon as it occurs.
- While the oven is still warm, sprinkle salt on the spill. If the spill is completely dry, wet it

lightly before sprinkling on salt. When the oven cools down, scrape away the spill and wash the area with a combination of vinegar and baking soda.

■ Retard grease buildup in your oven by dampening your cleaning rag in vinegar and water before wiping out your oven.

■ Sprinkle water followed by a layer of baking soda in your oven. Rub gently with a fine steel wool pad for tough spots. Wipe off scum with dry paper towels or a sponge. Rinse well and wipe dry.

### Refrigerator

■ Turn off and unplug refrigerator. Remove all food and removable interior parts. To clean exterior and interior walls, dissolve 2 tablespoons baking soda in 1 quart warm water and wipe all surfaces. For stubborn spots, rub with a baking soda paste. Be sure to rinse with a clean, wet cloth. (This works well on other enamel-finished appliances as well.) To clean interior fixtures, such as vegetable bins and shelves, wash in

hot soapy water, rinse well, and dry. Fresh lemon juice in the rinse water removes soap film.

### Sink (Porcelain Enamel)

■ Do not leave acid foods such as citrus fruits, cranberries, vinegar, or salad dressings on the sink's surface for a long time. Many porcelain-on-cast-iron sinks made before 1964 were not acid-resistant. Many acid foods etch even acid-resistant porcelain enamel if left in the sink a long time. A perforated rubber or plastic mat will protect a sink from damage. Try using a baking soda paste or vinegar on stains, then wipe clean.

### Sink (Stainless Steel)

■ A perforated rubber or plastic mat in the sink will cut down on scratching and marking by pans and tableware. Wash sink with a solution of hand dishwashing liquid detergent and water or a solution of baking soda and water. Rinse and polish dry with paper towels or a soft cloth. Never use scouring powder or steel wool on stainless steel as it will scratch. Rub stainless steel sinks with olive oil to remove streaks. To clean and polish stainless steel, simply moisten a cloth with undiluted white or cider vinegar and wipe clean. Vinegar can also be used to remove heat stains on stainless steel cutlery.

### Wooden Surfaces

■ Stains and odors can be removed by rubbing them with a cloth dipped in lemon juice. If the stains are stubborn, use a solution of ammonia and water.

■ You can make small scratches on finished wood surfaces less noticeable by mixing equal parts lemon juice and oil and rubbing it into the scratches with a soft cloth.



# Bathroom Cleaning

## Fiberglass Tub and Shower

■ Make a paste of baking soda and water. Wet the surface of tub or shower stall; gently rub with the paste on a sponge or soft nylon brush. Rinse thoroughly. Never use an abrasive cleaner (such as common scouring powder), any abrasive scouring pad, steel wool, or a scraper.

## Toilet Bowl

■ Sprinkle baking soda into the bowl, then drizzle with vinegar and scour with a toilet brush. This combination cleans and deodorizes.

## Tub and Tile

■ Sprinkle baking soda in place of scouring powder in your tub or on the tiles. Rub with a damp sponge. Rinse thoroughly.

■ To remove film buildup on bathtubs, apply full-strength vinegar to a sponge and wipe the area. Next, use baking soda as you would scouring powder. Rub with a damp sponge and rinse thoroughly.

■ Vinegar removes most dirt without scrubbing and doesn't leave a film. Use 1/4 cup (or more) vinegar to 1 gallon water.

■ To clean grout, put 3 cups baking soda into a medium-size bowl and add 1 cup warm water. Mix into a smooth paste and scrub into grout with a sponge or toothbrush. Rinse thoroughly and dispose of leftover paste when finished.

# Cleaners

## All-Purpose Cleaners

■ Mix together vinegar and salt for a good surface cleaner.

■ Dissolve 4 tablespoons baking soda in 1 quart warm water for a general cleaner. Or use baking soda on a damp sponge. Baking soda will clean and deodorize all kitchen and bathroom surfaces.

## Drain Cleaners and Drain Openers

■ To avoid clogging drains, use a drain strainer to trap food particles and hair; collect grease in cans rather than pouring it down the drain; pour a kettle of boiling water down the drain weekly to melt fat that may be building up in the drain;

or weekly put some vinegar and baking soda down your drain to break down fat and keep your drain smelling fresh.

■ A time-honored drain opener is the plunger. This inexpensive tool will usually break up the clog and allow it to float away. It may take more than a few plunges to unclog the drain.

## Floor Cleaners and Polishes

■ A few drops of vinegar in the cleaning water will help remove grease particles. Dull, greasy film on no-wax linoleum can be washed away with 1/2 cup white vinegar mixed into 1/2 gallon water. Your floor will look sparkling clean.

■ Polish your floor with club soda to make it sparkle.

■ For day-to-day cleaning of linoleum, damp mop using a mild detergent and water. Keep water away from seams and edges to prevent loosening of the tiles. To preserve the linoleum floor, you may wish to add a capful of baby oil to the mop water.

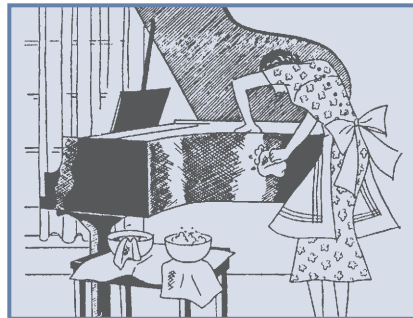

■ For brick and stone floors, mix 1 cup white vinegar into 1 gallon water. Scrub the floor with a brush and the vinegar solution. Rinse with clean water.

## Furniture Polish

■ Mix 2 parts vegetable or olive oil and 1 part lemon juice. Apply and polish with a soft cloth. This leaves furniture looking and smelling good.

## Grease Removers

■ If oil or grease is spilled on porch or patio cement, immediately apply an absorbent powder such as dry cement, cornmeal, or sawdust to absorb as much grease as possible. Leave it on the stain for a few hours and sweep up.

## Laundry Aids

■ Eliminate soap residue by adding 1 cup of white vinegar to the washer's final rinse. Vin-

egar is too mild to harm fabrics but will dissolve alkalies in soaps and detergents. Vinegar also breaks down uric acid, so adding 1 cup of vinegar to the rinse water is especially good for babies' clothes. Do not use vinegar if you add chlorine bleach to your rinse water. It will produce harmful vapors.

■ Add 1/4 to 1/2 cup baking soda per wash load to make clothes feel soft and smell fresh.

■ To remove smoke odor from clothes, fill your bathtub with hot water. Add 1 cup white vinegar. Hang garments above the steaming bath water.

## Rust Removers

■ To remove rust from tinware, rub with a peeled potato dipped in a mild abrasive such as baking soda or salt.

■ Mix 1 tablespoon lemon juice with 2 tablespoons salt to make a rust-removing scrub.

■ Briskly scrub rust spots on car bumpers with a piece of crumpled aluminum foil, shiny side out. This also works well on the chrome shafts of golf clubs.

## Window and Glass Cleaners

■ 1/2 cup vinegar to 1 gallon of water (or 2 tablespoons per quart)

or

1/2 cup ammonia to 1 gallon water (or 2 tablespoons per quart)

or

1/2 cup ammonia

2 cups rubbing alcohol

1 teaspoon liquid dishwashing detergent

1 gallon water

This solution is less likely to freeze in cold weather and works on extra-heavy soil and grease buildup. Dry with a soft cloth. Leaves windows and glass streakless.

or

Mix 1 tablespoon lemon juice in 1 quart water. Apply to surface and wipe dry.

■ Remove stains and discoloration on windows and glass and make scratches less noticeable with toothpaste. Rub a little toothpaste onto the stain or scratch. Polish with a soft cloth.

■ To clean cut glass, use a damp rag sprinkled with baking soda. Rinse with clean water and polish with a soft cloth.

## Relative Hardness of Woods

(HARDEST TO SOFTEST)

- |           |                        |               |
|-----------|------------------------|---------------|
| 1 Hickory | 6 Southern yellow pine | 10 Poplar     |
| 2 Oak     | 7 Cherry               | 11 White pine |
| 3 Maple   | 8 Elm                  | 12 Red cedar  |
| 4 Birch   | 9 Douglas fir          | 13 Balsa      |

The black walnut is a tree that is not difficult to raise, and it furnishes a timber that will always command a good price.

—The Old Farmer's Almanac, 1886

# A HOMEOWNER'S GUIDE TO WOOD

FROM  
THE OLD  
FARMER'S ALMANAC

## Guide to Lumber and Nails

### Lumber Width and Thickness in Inches

NOMINAL SIZE	ACTUAL SIZE Dry or Seasoned
1x3	¾x2½
1x4	¾x3½
1x6	¾x5½
1x8	¾x7¼
1x10	¾x9¼
1x12	¾x11¼
2x3	1½x2½
2x4	1½x3½
2x6	1½x5½
2x8	1½x7¼
2x10	1½x9¼
2x12	1½x11¼

### Nail Sizes

The nail on the left is a 5d (penny) finish nail; on the right, a 20d common. The numerals below the nail sizes indicate the approximate number of common nails per pound.

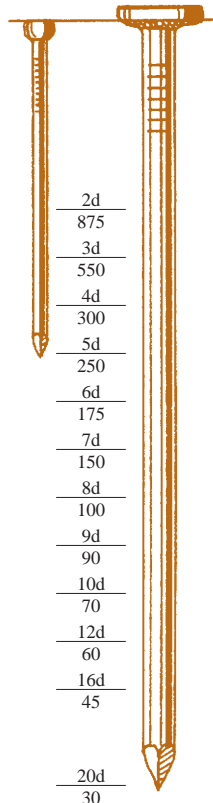

## What is a Board Foot?

A board foot is the measure by which lumber is sold. It consists of 144 cubic inches of wood — a quantity most easily visualized as a slab of wood one foot long, one foot wide, and one inch thick. In other words, when you're working with one-inch boards, a board foot and a square foot are the same thing. Double the thickness, and you halve the square footage needed to make up a board foot. A 12-inch length of 2x6, for example, also contains one board foot of wood.

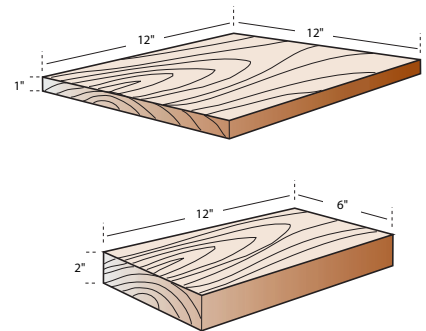

The simplest way to calculate board footage is first to decide how many linear, or running, feet of a given material you need. Multiply that figure by the constant that expresses the relationship between running feet and board feet, and the result is total board footage. The appropriate constants for some common lumber sizes appear in the table below:

### Converting Running Feet to Board Feet

NOMINAL SIZE	BOARD-FOOT CONSTANTS
--------------	----------------------

(multiply by running feet to get board footage)

1x6	½
2x4	⅔
2x6	1
2x8	1⅓
2x10	1⅔
2x12	2

### Lumber Measure in Board Feet

LUMBER Size in Inches	LENGTH				
	12 ft.	14 ft.	16 ft.	18 ft.	20 ft.
1x4	4	4⅔	5⅓	6	6⅔
1x6	6	7	8	9	10
1x8	8	9⅓	10⅔	12	13⅓
1x10	10	11⅓	13⅓	15	16⅔
1x12	12	14	16	18	20
2x3	6	7	8	9	10
2x4	8	9⅓	10⅔	12	13⅓
2x6	12	14	16	18	20
2x8	16	18⅓	21⅓	24	26⅔
2x10	20	23⅓	26⅔	30	33⅓
2x12	24	28	32	36	40
4x4	16	18⅓	21⅓	24	26⅔
6x6	36	42	48	54	60
8x8	64	74⅓	85⅓	96	106⅔
10x10	100	116⅔	133⅓	150	166⅔
12x12	144	168	192	216	240

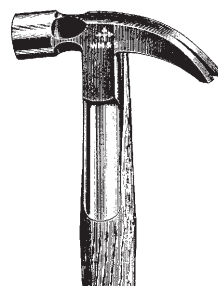

Age appears to be best in four things —  
old wood best to burn, old wine to drink, old  
friends to trust, and old authors to read.

—Francis Bacon (1561–1626)

## The Right Wood for the Job

Cabinet doors	Birch, cherry, maple, oak
Decking and outdoor steps	Locust, walnut, white oak
Doors	Birch, oak
Exposed platforms and porches	Locust, redwood, white oak
Exterior trim	Cedar, cypress, northern and Idaho white pine, ponderosa pine, redwood, sugar pine
Fence posts	Black locust, catalpa, cedar, chestnut, cypress, Osage orange, redwood, white oak
Frames and sashes	Cedar, cypress, northern and Idaho white pine, ponderosa pine, redwood, sugar pine
Gates and fences	Douglas fir, redwood, southern yellow pine, western larch, white oak
Interior trim, natural finish	Beech, birch, cherry, cypress, maple, oak, sycamore, walnut. Knotty surfaces: cedar, gum, lodgepole pine, ponderosa pine, spruce, sugar pine
Interior trim, painted finish	Northern and Idaho white pine, ponderosa pine, poplar, sugar pine
Paneling	Ash, birch, cedar, cypress, oak, pine, redwood, walnut
Plank roof decking	Douglas fir, southern yellow pine, other softwood
Roof sheathing	Douglas fir, southern yellow pine, western larch
Shelving	Ash, birch, Douglas fir, Idaho white pine, maple, oak, ponderosa pine, poplar, redwood, sugar pine, walnut
Shingles	Cedar, cypress, redwood
Siding	Cypress, redwood, western red cedar
Stairways	Ash, beech, birch, cherry, maple, oak, walnut
Subfloors	Ash, Douglas fir, oak, southern yellow pine, western larch
Wall sheathing	Aspen, balsam, basswood, cedar, hemlock, lodgepole pine, northern and Idaho white pine, ponderosa pine, poplar, redwood, spruce, sugar pine, white fir

## Homeowner's Tool Kit

### THE ESSENTIALS

Butt chisel	Curved-claw hammer	Bolts and nuts, hollow-wall fasteners, etc.
Putty knife	Push drill and drill point	Adhesives
Adjustable wrench	3 standard screwdrivers	Sharpening stone
Slip-joint pliers	(3 sizes)	Wire brush
Needle-nose pliers	2 Phillips screwdrivers	Paintbrushes
Block plane	(2 sizes)	Dustpan and brush
Four-in-one rasp	Combination square	Lint-free rags or cheesecloth
Hacksaw	Level	Clip-on light
Crosscut saw	Utility knife	Grounded extension cord
Sandpaper and steel wool	Toilet plunger	Single-edge razor blades
Retractable steel ruler	Screws and nails	with holder
Drain auger	<b>OTHER SUPPLIES</b>	Scissors
C-clamp	Machine oil	Toolbox
Nail set	Penetrating lubricant	Stepladder
	Pencils	

## Firewood Tips

- Freshly cut wood contains up to 50 percent moisture, and must be "seasoned" to 20 to 25 percent moisture content before burning. Wood containing more than 25 percent moisture is "wet" or "green" and should never be burned in a fireplace or woodstove.
- Wet wood is easier to split than dry wood.
- Wood must be cut into pieces and stacked out of the rain for at least six months to season properly.
- If steam bubbles and hisses out of the end grain as the firewood heats up on the fire, the wood is wet or green and needs to be seasoned longer before burning.
- Well-seasoned firewood generally has darkened ends with visible cracks or splits. It is relatively lightweight and makes a sharp, distinctive "clink" when two pieces strike each other.
- Limit the amount of pine you burn. It's a resinous, softwood.

## Firewood Heat Values

### High Heat Value

1 cord = 200–250 gallons of fuel oil

American beech  
Apple  
Ironwood  
Red oak  
Shagbark hickory  
Sugar maple  
White ash  
White oak  
Yellow birch

Douglas fir  
Red maple  
Silver maple  
Tamarack  
White birch

### Low Heat Value

1 cord = 100–150 gallons of fuel oil

Aspen  
Cottonwood  
Hemlock  
Lodgepole pine  
Red alder  
Redwood  
Sitka spruce  
Western red cedar  
White pine

### Medium Heat Value

1 cord = 150–200 gallons of fuel oil

American elm  
Black cherry

## How Many Trees in a Cord of Wood?

Diameter of Tree (breast high, in inches)	Number of Trees (per cord)
4	50
6	20
8	10
10	6
12	4
14	3

## A Few Clues About Cords of Wood

- A cord of wood is a pile of logs 4 feet wide by 4 feet high by 8 feet long.
- A cord of wood may contain from 77 to 96 cubic feet of wood.
- The larger the unsplit logs, the larger the gaps, with fewer cubic feet of wood actually in the cord.

# The Old Farmer's Almanac

# KITCHEN REFERENCE CHART

## Substitutions for Common Ingredients

ITEM	QUANTITY	SUBSTITUTION
Allspice	1 teaspoon	1/2 teaspoon cinnamon plus 1/8 teaspoon ground cloves
Arrowroot, as thickener	1-1/2 teaspoons	1 tablespoon flour
Baking powder	1 teaspoon	1/4 teaspoon baking soda plus 5/8 teaspoon cream of tartar
Bread crumbs, dry soft	1/4 cup 1/2 cup	1 slice bread 1 slice bread
Buttermilk	1 cup	1 cup plain yogurt
Chocolate, unsweetened	1 ounce	3 tablespoons cocoa plus 1 tablespoon butter or fat
Cracker crumbs	3/4 cup	1 cup bread crumbs
Cream, heavy	1 cup	3/4 cup milk plus 1/3 cup melted butter (this will not whip)
Cream, light	1 cup	7/8 cup milk plus 3 tablespoons melted butter
Cream, sour	1 cup	7/8 cup buttermilk or plain yogurt plus 3 tablespoons melted butter
Cream, whipping	1 cup	2/3 cup well-chilled evaporated milk, whipped; or 1 cup nonfat dry milk powder whipped with 1 cup ice water
Egg	1 whole	2 yolks
Flour, all-purpose	1 cup	1-1/8 cups cake flour; or 5/8 cup potato flour; or 1-1/4 cups rye or coarsely ground whole grain flour; or 1 cup cornmeal
Flour, cake	1 cup	1 cup minus 2 tablespoons sifted all-purpose flour
Flour, self-rising	1 cup	1 cup all-purpose flour plus 1-1/4 teaspoons baking powder plus 1/4 teaspoon salt
Garlic	1 small clove	1/8 teaspoon garlic powder or instant minced garlic
Herbs, dried	1/2 to 1 teaspoon	1 tablespoon fresh, minced and packed
Honey	1 cup	1-1/4 cups sugar plus 1/2 cup liquid
Lemon	1	1 to 3 tablespoons juice, 1 to 1-1/2 teaspoons grated rind
Lemon juice	1 teaspoon	1/2 teaspoon vinegar
Lemon rind, grated	1 teaspoon	1/2 teaspoon lemon extract
Milk, skim	1 cup	1/3 cup instant nonfat dry milk plus about 3/4 cup water
Milk, whole	1 cup	1/2 cup evaporated milk plus 1/2 cup water; or 1 cup skim milk plus 2 teaspoons melted butter
Milk, to sour	1 cup	Add 1 tablespoon vinegar or lemon juice to 1 cup milk minus 1 tablespoon. Stir and let stand 5 minutes.
Molasses	1 cup	1 cup honey
Mustard, prepared	1 tablespoon	1 teaspoon dry or powdered mustard
Onion, chopped	1 small	1 tablespoon instant minced onion; or 1 teaspoon onion powder; or 1/4 cup frozen chopped onion
Sugar, granulated	1 cup	1 cup firmly packed brown sugar; or 1-3/4 cups confectioners' sugar (do not substitute in baking); or 2 cups corn syrup; or 1 cup superfine sugar
Tomatoes, canned	1 cup	1/2 cup tomato sauce plus 1/2 cup water; or 1-1/3 cups chopped fresh tomatoes, simmered
Tomato juice	1 cup	1/2 cup tomato sauce plus 1/2 cup water plus dash each salt and sugar; or 1/4 cup tomato paste plus 3/4 cup water plus salt and sugar
Tomato ketchup	1/2 cup	1/2 cup tomato sauce plus 2 tablespoons sugar, 1 tablespoon vinegar, and 1/8 teaspoon ground cloves
Tomato purée	1 cup	1/2 cup tomato paste plus 1/2 cup water
Tomato soup	1 can (10-3/4 oz.)	1 cup tomato sauce plus 1/4 cup water
Vanilla	1-inch bean	1 teaspoon vanilla extract
Yeast	1 cake (3/5 oz.)	1 package active dried yeast
Yogurt, plain	1 cup	1 cup buttermilk

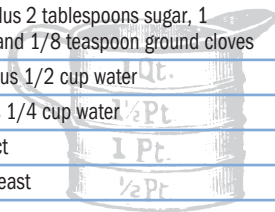

## MEASURING VEGETABLES

- Asparagus:** 1 lb. = 3 cups chopped
- Beans (string):** 1 lb. = 4 cups chopped
- Beets:** 1 lb. (5 medium) = 2-1/2 cups chopped
- Broccoli:** 1/2 lb. = 6 cups chopped
- Cabbage:** 1 lb. = 4-1/2 cups shredded
- Carrots:** 1 lb. = 3-1/2 cups sliced or grated
- Celery:** 1 lb. = 4 cups chopped
- Cucumbers:** 1 lb. (2 medium) = 4 cups sliced
- Garlic:** 1 clove = 1 teaspoon chopped
- Leeks:** 1 lb. = 4 cups chopped (2 cups cooked)
- Mushrooms:** 1 lb. = 5 to 6 cups sliced = 2 cups cooked
- Onions:** 1 lb. = 4 cups sliced = 2 cups cooked
- Parsnips:** 1 lb. unpeeled = 1-1/2 cups cooked and puréed
- Peas:** 1 lb. whole = 1 to 1-1/2 cups shelled
- Potatoes:** 1 lb. (3 medium) sliced = 2 cups mashed
- Pumpkin:** 1 lb. = 4 cups chopped = 2 cups cooked and drained
- Spinach:** 1 lb. = 3/4 to 1 cup cooked
- Squash (summer):** 1 lb. = 4 cups grated = 2 cups salted and drained
- Squash (winter):** 2 lbs. = 2-1/2 cups cooked, puréed
- Sweet Potatoes:** 1 lb. = 4 cups grated = 1 cup cooked, puréed
- Swiss Chard:** 1 lb. = 5 to 6 cups packed leaves = 1 to 1-1/2 cups cooked
- Tomatoes:** 1 lb. (3 or 4 medium) = 1-1/2 cups seeded pulp
- Turnips:** 1 lb. = 4 cups chopped = 2 cups cooked, mashed

## MEASURING FRUITS

- Apples:** 1 lb. (3 or 4 medium) = 3 cups sliced
- Bananas:** 1 lb. (3 or 4 medium) = 1-3/4 cups mashed
- Berries:** 1 quart = 3-1/2 cups
- Dates:** 1 lb. = 2-1/2 cups pitted
- Lemon:** 1 whole = 1 to 3 tablespoons juice; 1 to 1-1/2 teaspoons grated rind
- Lime:** 1-1/2 to 2 tablespoons juice
- Orange:** 1 medium = 6 to 8 tablespoons juice; 2 to 3 tablespoons grated rind
- Peaches:** 1 lb. (4 medium) = 3 cups sliced
- Pears:** 1 lb. (4 medium) = 2 cups sliced
- Rhubarb:** 1 lb. = 2 cups cooked
- Strawberries:** 1 quart = 4 cups sliced

## Table of Weights and Measures

### HOUSEHOLD MEASURES

- pinch = about 1/8 teaspoon
- 120 drops of water = 1 teaspoon
- 60 drops thick fluid = 1 teaspoon
- 2 teaspoons = 1 dessertspoon
- 3 teaspoons = 1 tablespoon
- 16 tablespoons = 1 cup
- 8 fluid ounces = 1 cup
- 16 fluid ounces = 1 pint
- 32 fluid ounces = 1 quart
- 128 fluid ounces = 1 gallon
- 2 cups = 1 pint
- 2 pints = 1 quart
- 4 quarts = 1 gallon
- 3 tablespoons flour = 1 ounce
- 2 tablespoons butter = 1 ounce
- 2 cups granulated sugar = 1 pound
- 3-3/4 cups confectioners' sugar = 1 pound
- 2-3/4 cups brown sugar = 1 pound
- 3-1/2 cups wheat flour = 1 pound
- 5-1/3 cups dry coffee = 1 pound
- 4 cups cocoa = 1 pound
- 6-1/2 cups dry tea = 1 pound
- 2 cups shortening = 1 pound
- 2 sticks butter = 1 cup
- 3 cups cornmeal = 1 pound
- 2 tablespoons sugar = 1 ounce
- 3-1/2 cups walnuts (chopped) = 1 pound
- 9 eggs = 1 pound
- 8 egg whites = 1 cup
- 16 egg yolks = 1 cup
- 1 ounce yeast = 1 scant tablespoon
- 60 apples = 1 bushel
- 52 beans = 1 bushel
- 24 beets = 1 bushel
- 56 carrots = 1 bushel
- 55 flour = 1 bushel
- 54 onions = 1 bushel
- 45 parsnips = 1 bushel
- 50 potatoes = 1 bushel
- 60 string beans = 1 bushel
- 60 sweet potatoes = 1 bushel
- 48 tomatoes = 1 bushel
- 196 turnips = 1 barrel

### METRIC

- 1/2 teaspoon = 3 milliliters
- 1 teaspoon = 5 milliliters
- 1 tablespoon = 15 milliliters
- 1 cup = 240 milliliters
- 1 quart = 0.946 liters
- 1 gallon = 3.785 liters
- 1 liters = 1.057 quarts
- 1 ounce = 28.35 grams
- 1 pound = 454 grams
- 1 gram = 0.035 ounces
- 1 kilo = 2.205 pounds
- 1 inch = 2.54 centimeters
- 1 centimeter = 0.39 inch

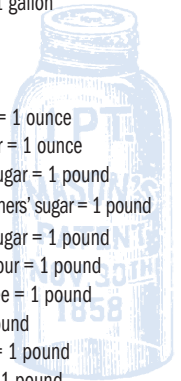

# The Old Farmer's Almanac

## Proverbs Relating to ANIMALS

- Expect rain when dogs eat grass, cats purr and wash, sheep turn into the wind, oxen sniff the air, and swine are restless.
- *If the bull leads the cows to pasture, expect rain; if the cows precede the bull, the weather will be uncertain.*
- When cats sneeze, it is a sign of rain.
- *When cattle lie down in the pasture, it indicates early rain.*
- Bats flying late in the evening indicates fair weather.
- *If the groundhog sees its shadow on Candlemas Day (February 2), six more weeks of winter remain.*
- When horses and cattle stretch out their necks and sniff the air, it will rain.
- *If the mole digs its hole 2½ feet deep, expect a severe winter; if two feet deep, not so severe; if one foot deep, a mild winter.*
- When pigs gather leaves and straw in fall, expect a cold winter.
- *When rabbits are fat in October and November, expect a long, cold winter.*
- If sheep ascend hills and scatter, expect clear weather.
- *Wolves always howl more before a storm.*

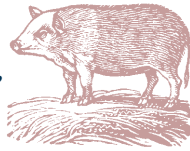

## Proverbs Relating to PLANTS

- When the ash leaves come out before the oak, expect a wet season.
- *Aspen leaves trembling in calm weather indicates an approaching storm.*
- When the bushes are full of berries, a hard winter is on the way.



- *Dandelion blossoms close before a storm.*
- Frost will not occur after the dogwood blossoms.
- *When the perfume of flowers is unusually perceptible, expect rain.*
- If autumn leaves are slow to fall, prepare for a cold winter. (Corn husks, apple skins, and nut shells are thought to be similar indicators.)

- *The sunflower raising its head indicates rain.*
- When the leaves of trees turn over, it foretells rain.

# GUIDE TO WEATHER PROVERBS and PROGNOSTICS

In a scientific paper written in 1882, meteorologists Ralph Abercromby and William Marriott sought to relate weather proverbs and folkways of forecasting the weather to actual atmospheric conditions. "The attempt to foretell the weather is not of recent date," they noted. "The ancients carefully studied the sky and clouds, and endeavored to predict the kind of weather that was likely to ensue. . . . In later times our forefathers studied the weather, and as they had no instruments to guide them, they observed natural objects and noticed the appearances of the sky and clouds, and also the movements of animals, birds, plants &c. Shepherds and sailors especially, being exposed to all kinds of weather, would naturally be on the lookout for any signs of a coming change, and after a time would begin to associate certain appearances with certain kinds of weather."



More than 100 years later, we still have the same interest in learning how to read nature's signs in order to forecast the weather. These weather proverbs and sayings are drawn from the files of *The Old Farmer's Almanac*. Although more than 200 years have passed since the Almanac's founding in 1792, many of these weather sayings are much older.

*Onion skins very thin,  
Mild winter coming in;  
Onion skins thick and  
tough,  
Coming winter cold and  
rough.*

## Proverbs Relating to BIRDS

**If birds in the autumn grow tame,  
The winter will be too cold for game.**



- Birds singing in the rain indicates fair weather approaching.
- *Partridges drumming in fall means a mild and open winter.*
- Chickens cackle and owls hoot just before rain.
- *If crows fly in pairs, expect fine weather; a crow flying alone is a sign of foul weather.*
- When fowls roost in daytime, expect rain.
- *The whiteness of a goose's breastbone indicates the kind of winter: A red or dark-spotted bone means a cold and stormy winter; few or light-colored spots means a mild winter.*
- When domestic geese walk east and fly west, expect cold weather.
- **Hawks flying high means a clear sky.  
When they fly low, prepare for a blow.**
- *Petrels gathering under the stern of a ship indicates bad weather.*
- **When the rooster goes crowing to bed,  
He will rise with watery head.**
- When sea gulls fly inland, expect a storm.

**When the swallow's nest is high,  
The summer is very dry;  
When the swallow buildeth low,  
You can safely reap and sow.**



## Proverbs Relating to RAIN

- Unusual clearness in the atmosphere, with distant objects seen distinctly, indicates rain.

**Red sky at morning, sailor take warning.  
Red sky at night, sailor's delight.**

**Evening red and morning gray  
Are sure signs of a fine day.  
Evening gray and morning red,  
Put on your hat or you'll wet your head.**

**If it rains before seven,  
It will clear before eleven.**

**Rain from the south prevents the drought,  
But rain from the west is always best.**

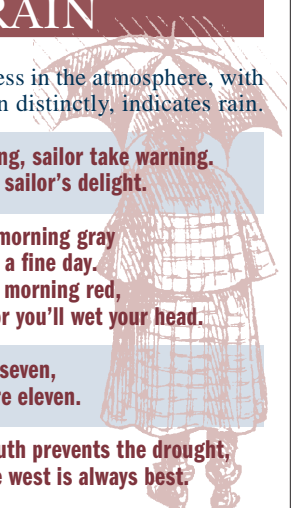

Proverbs Relating to

## INSECTS and REPTILES

**If ants their walls do frequent build,  
Rain will from the clouds be spilled.**

- Ants are busy, gnats bite, crickets sing louder than usual, spiders come down from their webs, and flies gather in houses just before rain.

**When bees to distance wing their flight,  
Days are warm and skies are bright;  
But when their flight ends near their home,  
Stormy weather is sure to come.**

- Fireflies in great numbers indicates fair weather.
- *When hornets build their nests near the ground, expect a cold and early winter.*
- When cicadas are heard, dry weather will follow, and frost will come in six weeks.

**When spiders' webs in air do fly,  
The spell will soon be very dry.**

- *Spiders in motion indicates rain.*
- When spiderwebs are wet with dew that soon dries, expect a fine day.

**Spiderwebs floating at autumn sunset  
Bring a night frost, this you may bet.**

- *The louder the frogs, the more the rain.*
- Frogs singing in the evening indicates fair weather the next day.
- *Leeches kept in glass jars are active just before rain.*
- Hang up a snakeskin and it will bring rain.

Proverbs Relating to

## DEW

**If three nights dewless there be,  
'Twill rain, you're sure to see.**

- If a heavy dew soon dries, expect fine weather; if it lingers on the grass, expect rain in 24 hours.

**With dew before midnight,  
The next day will sure be bright.**

- If you wet your feet with dew in the morning, you may keep them dry for the rest of the day.

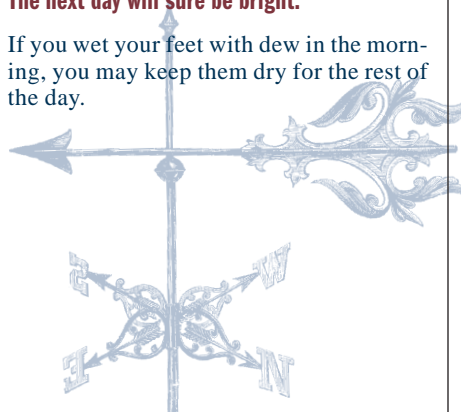

Proverbs Relating to

## THE MOON

- A full Moon in April brings frost.
- *In the old of the Moon a cloudy morning bodes a fair afternoon.*
- When the Moon runs high, expect cool or cold weather.
- *When the Moon runs low, expect warm weather.*
- When the horns of the Moon are sharp, it indicates dry weather.
- *The full Moon eats clouds.*
- Two full Moons in a calendar month bring on a flood.
- *A lunar halo indicates rain, and the number of stars enclosed, the number of days of rain.*



- If the new crescent Moon is turned up, the quarter will be dry. If the points are turned down, it will be wet.
- *The old Moon seen in the new Moon's arms is a sign of fair weather.*
- If the full Moon rises pale, expect rain. If the full Moon rises red, expect wind.

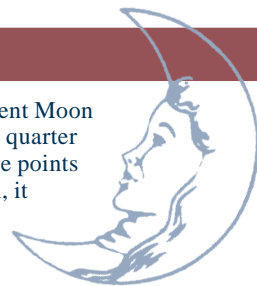

➤ *As many days old as the Moon is at the first snow, there will be as many snows before crop-planting time.*

Proverbs Relating to

## CLOUDS

**A cloud with a round top and flat base  
Carries rainfall on its face.**

- Anvil-shaped clouds bring on a gale.
- When small clouds join and thicken, expect rain.
- *Black clouds in the north in winter indicates approaching snow.*

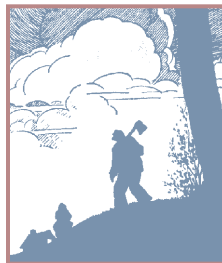

- When there is enough blue sky to patch a Dutchman's breeches, expect clearing weather.
- *A curdly sky will not leave the earth long dry.*
- If you see clouds going crosswind, there is a storm in the air.
- **Hen scarts and filly tails  
Make lofty ships wear low sails.**
- Clouds floating low enough to cast shadows on the ground are usually followed by rain.
- **Mackerel sky, mackerel sky,  
Never long wet, never long dry.**

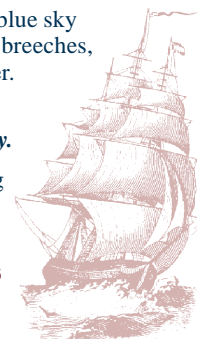

## WIND/BAROMETER TABLE

BAROMETER (REDUCED TO SEA LEVEL)	WIND DIRECTION	CHARACTER OF WEATHER INDICATED
30.00 to 30.20, and steady	westerly	Fair, with slight changes in temperature, for one to two days.
30.00 to 30.20, and rising rapidly	westerly	Fair, followed within two days by warmer and rain.
30.00 to 30.20, and falling rapidly	south to east	Warmer, rain within 24 hours.
30.20, or above, and falling rapidly	south to east	Warmer, rain within 36 hours.
30.20, or above, and falling rapidly	west to north	Cold and clear, quickly followed by warmer and rain.
30.20, or above, and steady	variable	No early change.
30.00, or below, and falling slowly	south to east	Rain within 18 hours that will continue a day or two.
30.00, or below, and falling rapidly	southeast to northeast	Rain, with high wind, followed within two days by clearing and colder.
30.00, or below, and rising	south to west	Clearing and colder within 12 hours.
29.80, or below, and falling rapidly	southeast to northeast	Severe storm of wind and rain imminent. In winter, snow or cold wave within 24 hours.
29.80, or below, and falling rapidly	east to north	Severe northeast gales and heavy rain or snow, followed in winter by a cold wave.
29.80, or below, and rising rapidly	going to west	Clearing and colder.

**Note:** A barometer should be adjusted to show equivalent sea-level pressure for the altitude at which it is to be used. A change of 100 feet in elevation will cause a decrease of 1/10 inch in the reading.

# Fascinating FISH FACTS and FOLKLORE

FROM *The Old Farmer's Almanac*

## Best Fishing Times

The best water temperatures for different fish species vary widely and are chiefly important if you are going to have your own fishpond. The best time for fishing for brook trout is when the temperature is 45° to 65°F (7° to 18°C). Brown trout and rainbow trout are more tolerant of warmer

temperatures. Smallmouth bass do best in cool water. Horned pout (bullheads) take what they find. Other best times:

■ **When the ocean tides are restless one hour before their turn and in the first hour of ebbing. All fish in all waters, salt and fresh, feed most heavily then. (Check *The Old Farmer's Almanac* for your area times.)**



### LARGEMOUTH BASS

*Micropterus salmoides*  
Average size:  
14–18 inches (36–46 cm)  
2–4 pounds (1–2 kg)



### SMALLMOUTH BASS

*Micropterus dolomieu*  
Average size:  
12–18 inches (31–46 cm)  
1½–4 pounds (1–2 kg)



### RAINBOW TROUT

*Oncorhynchus mykiss*  
Average size:  
8–18 inches (20–46 cm)  
1–4 pounds (0.5–2 kg)



### BROWN TROUT

*Salmo trutta*  
Average size:  
10–18 inches (25–46 cm)  
1–8 pounds (0.5–4 kg)

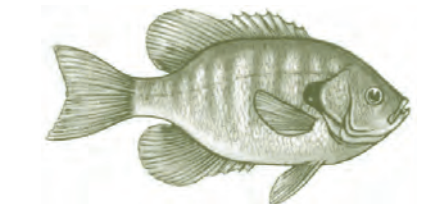

### BLUEGILL

*Lepomis macrochirus*  
Average size:  
7–10 inches (18–25 cm)  
½–1 pound (0.2–0.5 kg)

■ **When lake water is still or rippled, rather than during a wind.**

■ **When the breeze is from a westerly quarter, rather than from the north or east.**

■ **During the “morning rise” (after sunup for a spell) and the “evening rise” (just before sundown and the hour or so after).**

■ **When the barometer is steady or on the rise.**

■ **When there is a hatch of flies—caddis flies or mayflies, commonly.**

■ **The day the Moon is new and continuing through the day it is full.**

*To capture the fish is not all of the fishing.*

—Zane Grey, American author (1872–1939)



## What to Do When You Catch a Fish

1. Keep your line tight and your rod tip up. Slowly reel in the fish.
2. Hold the fish firmly with wet hands. Remove the hook by pushing it down and turning it so that it comes out the way it went in.
3. Carefully release the fish back into the water if it is not large enough to keep for food.
4. Keep caught fish alive by threading a stringer under the chin and through the lower lip. Let the fish swim in the water. Tie the other end of the stringer tightly to the boat or bank.



**PICKEREL***Esox reticulatus*Average size:  
15–26 inches (38–66 cm)  
1–4 pounds (0.5–2 kg)**ATLANTIC SALMON***Salmo salar*Average size:  
18–30 inches (46–76 cm)  
5–15 pounds (2–7 kg)**MUSKELLUNGE***Esox masquinongy*Average size:  
24–48 inches (60–120 cm)  
5–36 pounds (2–16 kg)**WALLEYE***Stizostedion vitreum*Average size:  
15–24 inches (33–50 cm)  
2–5 pounds (1–2 kg)**BROWN BULLHEAD***Ictalurus nebulosus*Average size:  
6–12 inches (15–31 cm)  
¼–1 pound (0.1–0.5 kg)

## How Do Fish ...

**SWIM?** Fish swim by flexing their body and tail (caudal fin) back and forth. They do this by expanding the muscles on one side of the body while relaxing the muscles on the other side, which propels them forward through the water.

**BREATHE?** Fish breathe by opening and closing their gill covers to pump water past the gills. They need a constant supply of oxygen, which they get from the water.

**SEE?** Fish see best at close range, with eyes that are similar to those of humans.

**SMELL?** Fish smell through two openings on their head. The sense of smell helps fish find food and warns of danger.

**TASTE?** Fish use taste buds, just as humans do. Some are on their tongue and others are on the outside of their body. The taste buds are able to distinguish between sweet, sour, salty, and bitter.

**HEAR?** Fish hear by picking up pressure changes and vibrations in the water through a lateral line (a system of thousands of tiny hair cells that run the length of the fish's body and work as a sensory organ) along each side of their body. The lateral line helps a fish find and capture food and avoid enemies.

**REPRODUCE?** Fish reproduce differently according to species but generally follow one of three methods. In most cases, a female drops eggs into the water, where they are immediately fertilized by sperm from a male. In the second method, the eggs are fertilized within the female's body before she drops them into the water. In the third method, the female retains the eggs within her body, and the young are born alive (some sharks and guppies give birth this way).

## Fish Quotes

*Never a fisherman need there be  
If fishes could hear as well as see.*

—Unknown

*There were lots of people who committed crimes during the year who would not have done so if they had been fishing, and I assure you that the increase in crime is due to a lack of those qualities of mind and character which impregnate the soul of every fisherman except those who get no bites.*

—Herbert Hoover, 31st U.S. president (1874–1964)

*Ever let your hook be hanging;  
where you least believe it, there will  
be fish in the stream.*

—Ovid, Roman poet (43 B.C.–A.D. 18)

*A man may fish with the worm that  
hath eat of a king, and eat of the  
fish that hath fed of that worm.*

—William Shakespeare, English playwright (1564–1616)

*Lord, suffer me to catch a fish so  
large that even I in talking of it af-  
terward shall have no need to lie.*

—Anonymous

*You must remember that there's  
plenty of salt in the sea to take with  
the tales your fellow fishermen tell.*

—John Hersey, American author (1914–1993)

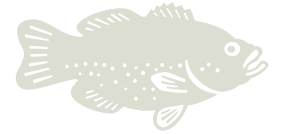
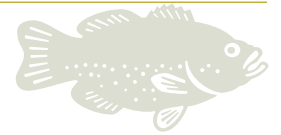
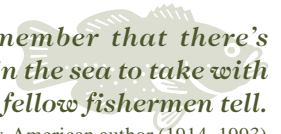
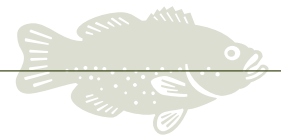

# Nothing is so clean as fish.

—Welsh proverb

## Fishing Tips

- Use binoculars to check ponds for areas where there are moving fish, especially trout.
- Fish in the early morning and late evening.
- Know the lake setup. Try to get as much information as possible about the terrain below the surface of the water.
- Remember that fish like to congregate on drop-offs and shallow ridges.
- Fish in heavy cover areas. This includes vegetation, rocks, and just about anything that provides shade for the fish.
- Be as quiet as possible when fishing. Excessive noise tends to spook the fish.
- Have ready a second strike rod—a rod with a different lure.
- Release a fish if it isn't large enough to eat.

## Lore for Luck

A fisherman always throws the first fish he catches back into the water for luck.

Always fish against the wind for luck.

Fish bite best at night, and if you play a fiddle or guitar, the fish just can't stay in the water but will come to the top because they love the music.

If you go fishing and see a big fish jump up, you will have bad luck all day.

If you let your shadow fall on the water while you are fishing, you will scare the fish away.

## Ice-Fishing Safety Tips

- Wear creepers. These spiked shoes will keep you from slipping and falling on the ice.
- Carry two picks to help pull your way out of the water if you fall through the ice. Once you spike your way out or are pulled out, don't stand. Roll across the ice in the direction you came from.
- Carry a buoyant seat cushion. It will add to your seating comfort while fishing and give you something that floats to throw to someone who has fallen through the ice.
- Keep your auger covered. The blades are sharp and can easily cut you.
- Spray vegetable oil on your auger and snowshoes. Snow won't stick, and you won't cut yourself when cleaning off the snow.

## Bait Advice

- Fish will not bite if you use a bright-colored cork on your line.
- If a dragonfly lands on your cork, quit fishing, for you will catch nothing.
- If you want to catch a two- or three-pound fish, always use a grasshopper for bait.
- To catch sunfish or perch, use salt pork for bait.
- When you lose your hook, tie bait on the line and continue fishing.
- Fish like shiny worms. Put worms in a can with some moss, sand, and cornmeal to polish them.

## Weather Superstitions and Folklore

*Wind from the south, hook in the mouth*

*Wind from the east, bite the least*

*Wind from the north, further off*

*Wind from the west, bite the best.*

*A cloudy day is a good time for fishing.*

*Catfish bite well when it thunders.*

*Fish on the west side of a bank if the wind is in the west.*

*If a fisherman goes out to fish, he should always pray  
For perpetual sunshine that will not fade away  
And he will have good luck all day.*

*If a rain comes slowly and falls gently, fish will continue to bite.*

*If the wind is in the south and it is cloudy, you can pull out fish as fast as you put your line in the water.*

## Tackle-Box Checklist

- ✓ Swivels, to keep fishing line from twisting
- ✓ Extra fishing line
- ✓ Stringer, to hold all the fish you plan to keep
- ✓ Different sizes of hooks
- ✓ Sinkers, to give your line enough weight for casting
- ✓ Bobbers, to keep your hook close to the surface of the water and to indicate when a fish is biting
- ✓ Pliers, to help remove hooks
- ✓ Sharp knife
- ✓ Ruler/scale
- ✓ Flashlight

A fishing rod is a stick with a hook on one end and a fool on the other.

—Proverb

## Know Your Knots

### CLINCH KNOT

The clinch knot is a popular and effective knot. It is also easy to master.

- Pass the line through the eye of the hook or swivel. Double back and make five turns around the line. Pass the end of the line through the first loop closest to the eye, and then through the large loop that you created as your line went through the first loop.

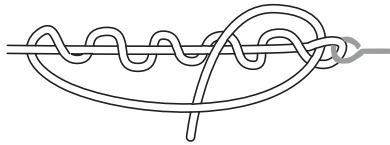

- Draw the knot into shape by sliding the coils tight against the eye.

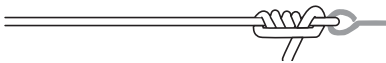

### PALOMAR KNOT

The palomar knot is a simple but strong knot. Its great virtue is that it can safely be tied in the dark with a minimum of practice.

- Double about six inches of line, and pass it doubled through the eye of the hook.
- Tie a simple overhand knot in the doubled line, letting the hook hang

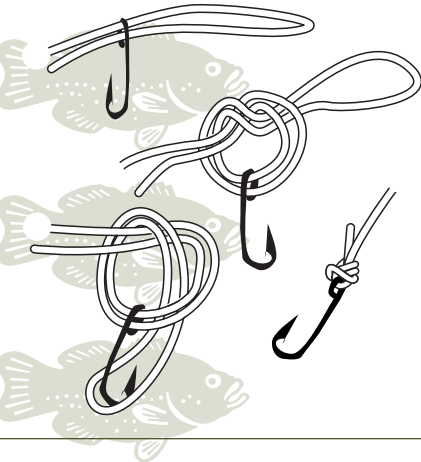

loose within the knot. Avoid twisting the lines.

- Pull the loop end down, and pass it completely over the hook.
- Pull the other doubled end of the line to draw up the knot.

### SNELLING KNOT

Ever wonder how they tie those fancy knots on the prepackaged hooks? Here's how it's done.

- Pass the end of the line through the eye of the hook twice in the same direction, leaving a loop slightly larger than the hook. Hold both lines along the shank of the hook.



- Use the loop to wind five to ten tight coils around the shank and both lines from the eye toward the hook end. Use your fingers to hold these tight coils in place. Pull the line (extending from the eye) until the whole loop has passed under the tight coils.



- With coils drawn up, use pliers to pull up the end of the line.

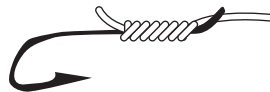

### BLOOD LOOP KNOT

You can tie an end loop quickly and easily using the blood loop knot. The loop can be made in the end of the line or in several places along the line to attach

swivels, hooks, weights, and leaders.

- Double the line back enough to make a loop of the desired size in the location you want to make the knot.

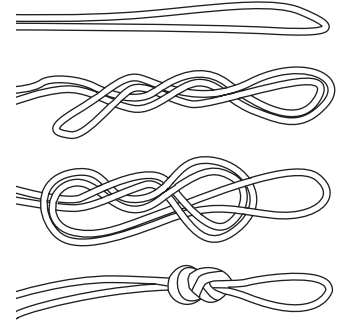

- Double back the loop and make two turns around the doubled line.
- Pass the end of the loop through the first loop formed when you doubled it back.
- Draw the knot up tight, pulling on both ends.

### SURGEON'S KNOT

The surgeon's knot is a good knot to use when you need to join two different line sizes.

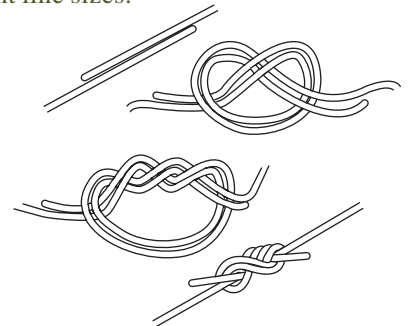

- Lay the two lines against each other, overlapping about ten inches.
- Working the two lines as one, tie an overhand knot.
- Pull one line (say the leader) completely through this loop again.
- Pass the other end through the loop and work the formed knot into shape.

*There are as good fish in the sea as ever came out of it.*

—English proverb

# The Old Farmer's Almanac GUIDE TO

TRADITIONAL

## Herbal Remedies

for • your

### BODY & MIND

#### Cautions

**N**atural" and "plant-based" don't necessarily mean harmless. With any herbal remedy, proceed with caution and moderation. Be sure you have correctly identified your plant materials. When in doubt, check with an expert. For safety, consult a qualified health practitioner before proceeding with any remedies.

If you are under a doctor's care for any reason; if you are nursing, pregnant, or trying to conceive; or if you have other "insinuating" conditions such as a heart condition or diabetes, consult with your doctor about any self-treatments you might be considering. Do not discontinue traditional prescribed medicines, or substitute home remedies for them, without consulting with your doctor.

Not all herbal remedies are suitable for children. Even those that are recommended for children (such as burdock, chamomile, catnip, dill, elderflower, eyebright, and fennel, to name just a few) should be used in children's doses, based on the age and/or weight of the child.

#### Colds

🌿 Rose hip tea is full of vitamin C and can help prevent colds.



🌿 Lemons, oranges, and apple cider are all considered to be cold remedies.

🌿 For chills, take fresh gingerroot.

🌿 Historically, the concentric layers of the onion were believed to draw contagious diseases from the patient into the bulb. Thus, an onion was often hung in a sickroom. Onions have antibacterial qualities.



onion

🌿 To cure a cold, cut up fresh garlic cloves and add them to chicken soup or other foods, or swallow small chunks of raw garlic like pills.

🌿 Prunes are a common cure for what ails us. They're rich in fiber, vitamins A and B, iron, calcium, and phosphorus. And they've been cured themselves!

🌿 To treat sore lips, go to bed with honey on them.

#### Anxiety and Stress

🌿 To ease anxiety, massage the temples with lavender oil or drink chamomile tea.

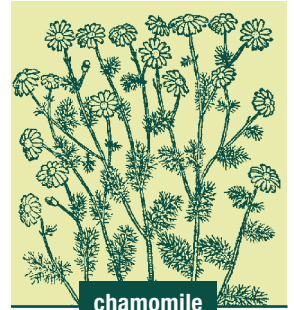

chamomile

🌿 Drink rosemary tea to alleviate melancholy or depression.

🌿 For a relaxing body rub, soak equal parts finely chopped dandelions, burdock (roots and/or aerial parts), yellow dock, and lobelia in 1 quart rubbing alcohol for at least two weeks. Apply externally, as needed.

*Patience is the best remedy for every trouble.*

—Plautus (254–184 B.C.)

🌿 Trying to remain relaxed but alert? Some studies suggest that the smell of apples, apple cider vinegar, or spiced apples (as in mulled cider) have this effect.



apple

🌿 A tea of elderberry flowers is considered relaxing to the nerves and is sleep inducing.

🌿 For insomnia, drink bee balm or chamomile tea and eat mandarin oranges.



#### Herbal Lore

**BASIL**  
good for the heart, head, and fertility

**FENNEL**  
for flattery and love potions

**MARJORAM**  
reduces sighing

**SAGE**  
domestic virtue and longevity

*Good health and good sense are two of life's greatest blessings.*

—Publius Syrus (c. 42 B.C.)

# Curing Colds

*A common saying about a cold is that it "lasts for a week if you treat it, seven days if you don't." As amusing and true as that may be, it's no fun to have a cold. What can we do to help our bodies through this seven-day healing process?*

- 🌿 The timeworn advice to rest and drink plenty of fluids is well-founded. A day off from work or home chores to take care of yourself at the beginning of the cold may protect you from having to take several days off later.
- 🌿 Drinking lots of fluids helps keep the body hydrated during times of dry indoor air; and hot soups (chicken, of course, to clear nasal passages) and herbal teas frequently bring relief.
- 🌿 Old-timers often turned to bizarre cures, such as wearing cooked onions in a cloth bag tied around the neck, or washing out the nose with cod-liver oil.
- 🌿 Eating foods heavy in garlic, or eating extra-spicy dishes, may speed recovery as well. But perhaps the best advice is simply to stay warm, rest, and wait. In seven days, we all have the same amount of time.

## The Old Wives Were Right

(FEED A COLD, STARVE A FEVER.)

*For a cold, take chicken soup steaming hot and seasoned with garlic.*

### Granny's Best Chicken Soup

- 4 quarts cold water
- 1 chicken (4 to 5 pounds), quartered
- 3 cloves garlic, peeled and crushed
- 1 medium onion, peeled and quartered
- 2 medium carrots, peeled and chopped
- 2 stalks celery, chopped
- 4 stems parsley
- 1 bay leaf
- 2 teaspoons salt
- ½ teaspoon freshly ground black pepper

Measure water into a large soup pot and add all the ingredients. Slowly bring to a boil over medium heat, then immediately reduce the heat and simmer for 3 hours, using a spoon to frequently skim the soup as well as possible. Remove from heat and cool. Skim fat from the surface and strain the soup. Wash out the soup pot and return the strained stock to the pot.

From strained ingredients, remove and discard bay leaf and parsley. Mash the remaining vegetables and stir them into the soup. Remove the skin and bones from the chicken, chop the meat, and add to the soup. (If the chicken meat has completely fallen apart, that's OK, too; just use as is, with skin and bones removed.) Heat and season to taste with additional salt and pepper.

*Makes 8 to 10 servings.*



Herbal Lore

SAVORY  
for comfort



THYME  
headache remedy

### Sore Throats

- 🌿 Gargle with a warm infusion of sage or rosemary, or with a tincture of purple coneflower.
- 🌿 Gargle with cool sage tea.
- 🌿 Make a syrup of horseradish, lemon juice, and honey to relieve a sore throat.



### Anticold Strategies

*If you're trying hard not to share colds and the flu, remember these tips:*

- Keep current on inoculations, and ask your doctor about flu shots.
- Wash your hands often, and don't share washcloths or towels.
- Use disposable tissues instead of cloth handkerchiefs.
- Don't bite your nails; it spreads germs.
- Don't share food or drinks, even a taste.
- When in doubt, hug instead of kiss.
- Eat healthy foods and drink plenty of water and juice.
- Get plenty of sleep.



CORIANDER SEED  
for immortality



DILL  
aids sleep and stops hiccups

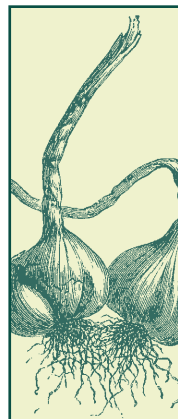

GARLIC  
for courage and against hydrophobia



MINT  
inspires love



NUTMEG  
freckle cure and eye aid

Herbal Lore

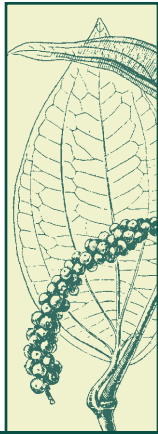

### Herbal Lore

PARSLEY  
*for memory*

PEPPER  
*an aphrodisiac*

POPPY SEED  
*symbol of sleep*

ROSEMARY  
*to restore youth  
and fidelity*

TARRAGON  
*sporicific and  
breath sweetener*

Eat spicy foods to cure respiratory infections. (The ancient Greek physician Hippocrates prescribed vinegar and peppers.) Hot and spicy foods act as expectorants, loosening up the lung's secretions and unclogging air passages.

### Brush Your Way to Health

Cinnamon toothpaste can be used for its antiseptic qualities to kill bacteria, fungi, and viruses.

## Fevers and Flu

To avoid fall fevers, eat moderately, drink sparingly, lie not down on the damp earth, nor overheat yourself; but keep your temper, and change your clothes as the weather changes.

—The Old Farmer's Almanac, 1852

For fever, take cayenne pepper (in food, broth, or tea) to warm the body, promote sweating, and enhance the body's infection-fighting ability.

Feverwort, *Eupatorium perfoliatum*, is also known as thoroughwort, Indian sage, and vegetable antimony. The Pennsylvania Dutch used it to induce sweating and drive down the high fevers and aches of the flu. Do not eat it fresh or give it to children.

For an intermittent fever, "drink warm lemonade in the beginning of every fit; it cures in a few days."

—John Wesley, *Primitive Remedies* (1776)

## Coughs

Lemon juice, sweetened with loaf or crushed sugar, will relieve a cough.

—The Old Farmer's Almanac, 1852

## Is It a Cold or the Flu?

SYMPTOMS	FLU	COLD	ALLERGY	SINUSITIS
Headache	Always	Occasionally	Occasionally	Always
Muscle aches	Always	Usually	Rarely	Rarely
Fatigue, weakness	Always	Usually	Rarely	Rarely
Fever	Always	Occasionally	Never	Occasionally
Cough	Usually	Occasionally	Occasionally	Usually
Runny, stuffy nose	Occasionally	Usually	Usually	Always
Nasal discharge	Occasionally	Usually	Usually	Always
Sneezing	Rarely	Occasionally	Usually	Rarely
Sore throat	Rarely	Usually	Occasionally	Rarely
Itchy eyes, nose, throat	Rarely	Rarely	Usually	Never



Drink mullein flower tea.

Catnip tea helps reduce mucus.

To suppress a night cough, put 1 teaspoon black pepper and 1 teaspoon sugar into a mug. Pour in boiling water and let steep. The pepper will settle to the bottom. Sip, as needed.

Horehound drops, from the bitter mint *Marrubium vulgare*, are made with the extract of the hoary, downy leaves of the plant. A symbol of health, horehound was used primarily as a cold remedy or for coughs. It makes a bitter tea, often served with lemon, or can be combined with honey for a soothing cough drop.

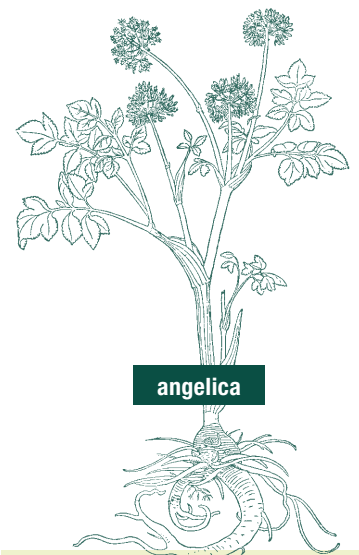

Herbs suggested to boost the immune system have included garlic, ginseng, rosemary, and angelica. (CAUTION: Angelica is easily confused, in amateur harvesting, with the poisonous water hemlock).



## More Relief from Herbs

### Calendula

🌼 Creams and balms of calendula are often effective as antiseptics and anti-inflammatory agents for chapped hands and lips and other minor skin irritations.

#### CALENDULA SALVE

**Steep chopped dried calendula flowers in olive oil for two weeks. Strain through muslin and add 4 parts melted beeswax to every 10 parts calendula oil. A few drops of benzoin tincture will help the salve keep well. Store in a covered container. Apply externally to scrapes and bruises.**

### Echinacea

🌼 Commonly known as purple coneflower, echinacea is an herb used in teas, capsules, and tinctures to enhance immunity to colds and the flu and to fight mucous infections. The root is the part generally used, although the flower can be used, as well.



echinacea

### Feverfew

🌼 For brainpower and enhanced memory, feverfew is a vasodilator that is considered to enhance blood circulation to the brain and, sometimes, relieve or prevent migraines. Avoid feverfew if you are pregnant or on blood thinners.

### Garlic and Onions

🌼 The “poor person’s antibiotic,” garlic and onions were used in Europe as far back as the Middle Ages and in China possibly as far back as the Neolithic period. Onions were used as a cold remedy by American colonists.

### Goldenseal

🌼 Goldenseal tea (about 1/4 teaspoon of dried leaves in a cup of hot water) has astringent, antibacterial, and antiviral effects and may be taken as a short-term cold remedy or immunity booster. Avoid it if you are pregnant or have high blood pressure.



ginseng

In Chinese folk medicine, ginseng has gained a reputation as a veritable cure-all. Here are a few reputed uses for ginseng:

- to aid digestion
- to stimulate the blood
- for insomnia
- for stiffness in the joints
- for short-windedness
- to avert depression
- for headache
- for colds

### Rosemary

🌼 A symbol of remembrance, fidelity, and friendship, rosemary was used in teas to quiet the nerves and restore memory. Greek students wore it in their hair for better memory. Bathing in it was thought to restore youth. Many still use it as a hair rinse, for halitosis, against moths, and as a general fumigant.



rosemary

### St. John's-Wort

🌼 St. John's-wort flowers in a tea are reputed to ease depression and calm the nerves. The herb is an expectorant, analgesic, antibacterial, and antiviral and is often considered to be a remedy for sore throats and cold symptoms.



St. John's-wort

### Mint Refresher

Boil together 1 pound sugar and 1 quart water. Chop 1 to 2 cups mint leaves very fine, then grind with a mortar and pestle, adding about 1/4 cup sugar to the grinding. Once the boiled sugar has cooled, add the mint and the juice of 3 to 5 lemons. Chill before drinking.



A special thanks to Martha White, author of *Traditional Home Remedies* (Time-Life Books, 1997).

# The Old Farmer's Almanac

# Guide to Herbs & Spices

**HERBS** are the leaves of plants (fresh or dried).

**SPICES** are the seeds, flesh, flowers, bark, roots, or berries of specific plants (almost always dried).



## CARAWAY SEED

Prescribed for pale-faced girls, caraway also scented perfumes, mouth rinses, and soaps. The Greeks used caraway to ease an upset stomach and fed it to pigeons to keep them from straying.

**The seeds are sharp-tasting and pungent.**

**Use in rye breads, cheese dips and rarebits, soups, applesauce, salads, and coleslaw, and over pork or sauerkraut.**

## CARDAMOM, Green

Bedouin coffee depends on cardamom for its exotic flavor. The opened pods are stuffed in the spouts of brass coffee urns. Old-timers chew it for sweetening the breath.

## CARDAMOM, Ground

Cardamom, related to ginger, was used in old recipes for pickled vegetables, fruits, and herring; custards; spiced wines; liqueurs; and even sauerbraten.

**Has a mild ginger flavor.**

**It can be used in cakes and pastries (use it instead of nutmeg in pumpkin pie), curries, jellies, and sweet potatoes.**

## CAYENNE (Red) PEPPER

"If a mouse makes an entrance, saturate a rag with cayenne and stuff it in the hole. No rat or mouse will eat that rag to open communication with a depot of supplies in the buttery." (1888 *Old Farmer's Almanac*)

**Tastes like a blend of hot chili peppers.**

**Highly pungent. Use sparingly in sauces, soups, curries, and stews, and with meat or seafood dishes.**

## CELERY SEED

Celery seed is welcomed in salads and wherever a bit of bitterness is desired. Seventeenth-century Italians developed the parent plant, celery, from a wild salt-marsh plant called smallage or small ache.

**Tastes like celery.**

**Use with vegetables, eggs, meat, fish, and poultry.**

## CHERVIL

Related to parsley and native to southern Russia, chervil is reported to warm and

comfort a cold, weak stomach. Its botanical name means "the heart rejoices."

**Has a mild parsley flavor.**

**Use in soups, salads, and sauces, and with eggs, fish, veal, lamb, and pork.**

## CHILI PEPPERS, Whole and Powdered

For ague or against the common cold, Texans and Mexicans chewed whole chili peppers. Columbus found these, along with allspice, on his early spice quests.

**Commercial chili powder is usually a blend of sweet and/or hot chilies and other spices.**

**Use in Mexican dishes, gravies, stews, and scrambled eggs, and with shellfish.**

## CHIVES

Cultivated in the Middle Ages, chives grew wild long before that.

**Have a delicate onion flavor.**

**Related to the onion, chives enliven vegetable dishes, dressings, casseroles, rice, eggs, cheese dishes, sauces, gravies, and dips.**

## CILANTRO, Fresh

The leaves of the coriander plant, cilantro was once thought to prevent baldness. Pregnant women have better luck sowing it, some say.

**Has a mild parsley flavor.**

**Use in soups, salads, curries, and as a garnish.**

## CINNAMON

An appetite stimulant, cinnamon has been used as a perfume and in sacred oils. A folklore cure for the common cold was to sniff cinnamon. Cinnamon sticks (the bark of the cinnamon tree, native to Ceylon) were used by colonial Americans as a digestive and to flavor or "mull" cider.

**Has a warm, spicy flavor.**

**Use ground cinnamon in baked goods, stewed fruits, vegetables, and spiced teas and coffees.**

## CLOVES

To cure toothaches, to scent closets, or to repel moths, colonists looked to whole cloves. They grow only near the sea, particularly on Zanzibar and Madagascar and in the West

## ALLSPICE

Columbus found allspice (the symbol of compassion) in the West Indies in 1493. His ship's physician noted that the tree had the "finest smell of cloves" that they had ever encountered. A member of the pepper family, allspice is known in Caribbean cooking as Jamaica pepper. In Poland it's called *kubaba*.

**Tastes like a blend of cinnamon, nutmeg, and cloves.**

**Use in pot roasts, stuffings, cakes, biscuits, pies, and relishes.**

## ANISE SEED

Considered good for digestion, anise was used to flavor cough drops, homemade spirits, and tonics. In 13th-century England the tax on anise paid for repairs to London Bridge.

**Has a sweet licorice flavor.**

**Use in cookies, cakes, fruit fillings, and breads; with cottage cheese; and in shellfish and spaghetti dishes.**

## BASIL, Sweet

Good for the head, heart, and fertility, basil is considered sacred in India and precious to lovers in Italy. Romans cursed basil while sowing to ensure a good crop.

**Has a mild mint-licorice flavor.**

**Use in tomato dishes, pesto, sauces, and salad dressings.**

## BAY LEAVES

Thought to deter lightning, witches, and the devil, bay leaves were also used for laurel crowns to mark wisdom and victory. Under your pillow, bay leaves bring good dreams.

**Tastes woody, pleasantly bitter.**

**Use with meat, fish, poultry, and sauces.**



Indies. Their scent can be detected at sea even before land is sighted.

**Have a hot, spicy flavor.**

**Use in baked goods, curries, baked beans, and beef stew, and as a pickling spice.**

## CORIANDER SEED, Whole and Ground

The name comes from the Greek *koris*, meaning bug. Old perfumes and colognes used its scent, and it flavored bitter medicines. The Chinese believed that it brought immortality. The fresh leaves of the plant (cilantro) have quite a different flavor than the seeds.

**Has a pleasant orange-lemon flavor.**

**Use with curries, meat pies, sausage, fish, breads, cream or pea soups, and artichokes.**

## CUMIN SEED, Whole and Ground

A sign of greed in Greece, elsewhere cumin was fed to lovers to keep them faithful. Related to the carrot family, cumin is used as a bread ingredient in Italy and Germany to protect the loaves from being stolen by wood spirits. Hens fed with cumin stay close to home.

**Has a salty-sweet flavor. Reminds of caraway.**

**Use whole in yogurt dishes, soups, and breads, or ground in pork, rice, sausage, and chili and curry dishes.**

## DILL, Fresh and Seed

This herb takes its name from the Saxon *dilla* for “to lull.” “Vervain and dill hinder witches at their will,” said some, but elsewhere dill seasoned witches’ brew. The English boiled it in wine and inhaled the aroma to stop hiccups.

**Tastes sweeter and milder than caraway.**

**Use seed for pickles and also to add aroma and taste to strong vegetables like cauliflower, cabbage, and turnips. Fresh is good with green beans, potato dishes, cheese, soups, salads, seafood, and sauces.**

## FENNEL

In the Middle Ages, monks flavored their foods with fennel. Because they often received compliments for their tasty meals, fennel became a symbol of flattery. Fennel has been used in love potions, and some believe that the seed can be made into a weak tea for colicky babies.

**Has a mild licorice flavor.**

**Use to flavor pastries, confectionery, sweet pickles, sausages, tomato dishes, and soups, as well as vinegars and oils. Gives warmth and sweetness to curries.**

## FENUGREEK, Ground

From the Latin for “Greek hay,” fenugreek is native to India and southeastern Europe.

Its flavor becomes stronger after roasting. Used as one of the main ingredients in curry powders.

**Has a bitterly aromatic flavor.**

**Use in soups, stews, gravies, or sauces. The seeds can also be used in pickles and chutneys.**

## GARLIC

Romans ate it for courage and Bolivian bullfighters carried it into the ring. Aristotle believed that garlic cured hydrophobia, the fear of water. Folklore advises hanging whole bulbs around the neck to cure a cold. (It’s probably more effective just to eat it.)

**Pungent, aromatic, mild-to-biting taste raw; mellow when cooked.**

**Use in tomato dishes, garlic bread, soups, dips, sauces, and marinades, and with meats, fish, and vegetables.**

## GINGER

Ever since medieval times, ginger has been used to flavor gingerbread. In the 14th century, it was used to guard against plague during the Black Death. In the 1800s, a tincture of ginger was used as an “expellant to purgative draughts” and to cure seasickness.

**Has a sweet, spicy flavor.**

**Use in pies, pickles, puddings, cookies, cakes, cheese dishes, salad dressings, and soups. It is an important ingredient in Chinese, Indian, and Arab dishes.**

## JUNIPER BERRIES

In 17th-century England, juniper berries were tossed into fireplaces to sweeten the air. Although the berries are used to season meat and fish dishes, they are perhaps best known for providing the basic flavor in gin.

**Has a bitter-tart taste.**

**Use in sauerkraut dishes and marinades for game. A few berries reduce the wild flavor of game and add a nice tartness to the dish.**

## LOVAGE, Fresh and Seed

Native to southern Europe, lovage was widely used by the Greeks and Romans. It can grow up to seven feet high. Both the leaves and the seeds can be used.

**Tastes like lemon-scented celery.**

**Use in soups, stews, and salad dressings. Goes well with potatoes. The seeds can be sprinkled on breads and biscuits.**

## MACE

The dried, netlike covering (“aril”) of nutmeg, mace comes in pressed, flat blades when fresh. It is most commonly used ground. Old recipes used mace sparingly (often with cherries) because it was quite precious.

**Has a soft nutmeg flavor.**

**Use in doughnuts and other baked goods, sauces, with chicken, creamed fish, seafood, and fruits.**

## MARJORAM

*The Old Farmer’s Almanac* once suggested marjoram for those “given to overmuch sighing.” The Greeks believed that it could revive the spirits of anyone who inhaled it.

**Has a delicate, flowery taste reminiscent of oregano and thyme.**

**Use in almost any meat, fish, dairy, or vegetable dish that isn’t sweet. Add near the end of cooking.**

## MINT LEAVES, Fresh and Dried

Thought to inspire love, mint was one of the herbs brought by the Pilgrims to the New World.

**Has a fruity taste.**

**Use with roast lamb or fish, and in salads, jellies, or teas. It is common in Middle Eastern dishes.**

## MUSTARD, Ground Hot

Mustard, from the Latin *mustum ardens* for “burning must,” was once thought to prevent balding. The ancient Greeks and Romans pulverized it and sprinkled it on their food.

**Has a sharp, hot, spicy flavor.**

**Use in spicy sauces for cocktail meatballs, and on fried shrimp, ham, corned beef, cold cuts, and your favorite hot dog. Add a pinch to gingerbread and to cheese sauces.**

## MUSTARD SEED

Mustard seed was commonly used in plasters or poultices to reduce congestion and alleviate joint stiffness.

**Has a pungent, spicy taste.**

**Use for pickling or in tomato or vegetable dishes. Crush in salads and coleslaw, spiced meats, boiled and corned beef, and curries.**

## NUTMEG

Resembling the brain in appearance, nutmeg was once considered good for head ailments and eyesight. Some old-timers used nutmeg to remove freckles. In 1760, large quantities were burned in Amsterdam to keep prices high.

**Has a spicy, sweet taste.**

**Use in cakes, custards, pies, applesauce, eggnog, soufflés, and meat and vegetable recipes.**

## OREGANO

Related to wild marjoram, oregano was used to aid digestion. Oregano tea eases coughs and sore throats.

Tastes zesty and strong, more pungent than marjoram; is reminiscent of thyme.

Use in any tomato dish, and with summer squash and potatoes, mushroom dishes, beans, or in a marinade for lamb or game.

## PAPRIKA

The national spice of Hungary and essential to goulash and other meat stews, Hungarian paprika, made from the dried flesh of sweet red peppers, has a bright-red color.

Has a spicy-sweet flavor. Milder than chili powder and cayenne.

Use in stews, salad dressings, and omelets, and with fish.

## PARSLEY

Good for memory, parsley blends well with other herbs and spices. Give it away and you give away your luck. Don't cut it if you are in love or take it as a gift.

Has a sweet, clean flavor.

Use fresh in soups, sauces, and salads. (It lessens the need for salt in soups.) Fry it and use it as a side dish with meat or fish. It is, of course, the perfect garnish.

## PEPPER, Black

The sun-dried berry of the tropical vine *Piper nigrum*, black pepper is native to the Malabar coast of India. It's an aphrodisiac, some say. A form of wealth in the Middle Ages, pepper was used to pay taxes and dowries.

Has a pungent, spicy taste. It is appropriate for all culinary uses.

Use it to preserve meat. It enhances almost any dish and aids digestion. If possible, buy whole peppercorns and grind as needed.

## PEPPER, Crushed Red

A member of the *Capsicum* family, red pepper was traditionally thought to grow best if planted while the gardener was in a rage. (See Cayenne.)

Has a slightly spicier flavor than black pepper.

## PEPPER, Szechuan

The small red fruits of the Chinese pepper tree (native to China and Taiwan) are ground and roasted. Szechuan pepper is a key ingredient in Chinese five spice powder.

Slightly milder taste than a chili pepper.

Use in Chinese cooking.

## PEPPERCORNS, Pink

Pink peppercorns are the semi-ripe berries of the South American peppertree plant (*Schinus molle*).

Has a milder taste than either black or green peppercorns.

Use to season fish and veal. For visual appeal,

sprinkle ground pink peppercorns on salad greens.

## PEPPERCORNS, White

The outer skin of the black pepper is removed to make the white peppercorn.

Has a bit less pungent taste than black peppercorns.

Use for fish, poultry, and white vegetables.

## POPPY SEED

A symbol of sleep, poppies grow where battles raged and where England's holy maid Margaret slew the dragon.

Has a sweet, nutlike flavor.

Use in breads, cakes, pastries, and salad dressings. Try also with vegetables and noodles.

## ROSEMARY

The word comes from *ros* (dew) and *marinus* (sea). Rosemary is one of the most common plants on the hillsides in the Mediterranean close to the sea. Bathing in rosemary was advised to restore youth and clear the complexion. It was commonly used to ensure fidelity, friendship, and sound sleep.

Has a sweet, resinous flavor.

Use with poultry, lamb and tomato dishes, stews, soups, and vegetables. Try it finely chopped in breads and custards.

## SAFFRON

This expensive spice comes from the orange and red stigmas of a purple crocus. The best saffron is grown in Spain.

Has an exotic, bittersweet taste.

Soak saffron in warm liquid before adding to a dish. Use in rice and seafood dishes. Try it in breads, pastries, cream soups, and sauces. Just a few threads will add a golden color to food.

## SAGE

Domestic virtue was linked with sage. This was the herb of Zeus and was thought to promote strength and longevity. Its name comes from the Latin for "save." It has been said to quicken the sense of memory and take away trembling.

Is pungent and warm tasting.

Use in cheese dishes, stuffings, soups, pickles, and salads, and with beans and peas, and in salads. Excellent for salt-free cooking.

## SAVORY, Summer

For comfort, for aroma, for bees in their hives, and for dishes with beans, savory was the choice.

Has an aromatic, peppery taste.

Use in soups, stews, and stuffings, and with fish, chicken, green beans, and eggs.

## SESAME SEED

"Open, Sesame!" is what Cassim forgot in Ali Baba's tale. In East India, the seeds found culinary and ceremonial uses, including rituals for burial and fertility.

Has a nutlike flavor when toasted.

Use the white seeds in breads, rolls, and cookies. Use the black seeds in Asian cooking to coat meat and fish before cooking and to season rice and noodle dishes.

## STAR ANISE

The fruits and seedpod of a Chinese evergreen, star anise was brought to Europe by a 16th-century English sailor. The oil, extracted by steam, flavors liqueurs.

Has a spicy licorice flavor.

Use in classic Chinese cooking (a must for duck and pork recipes) and marinades. Gives a sweet licorice flavor to teas and coffees.

## TARRAGON

Related to mugwort and wormwood, tarragon means "little dragon," from the serpentine appearance of its roots. It was considered soporific and good for the breath.

Has a slightly bitter, anise-licorice flavor.

Use with meats, eggs, poultry, and seafood, and in salad dressings, marinades, and sauces.

## THYME

*The Old Farmer's Almanac* once published this 15th-century folk remedy for headache: "Heat hillwort [thyme] and sysell [vinegar], and put it in your nostrils that the odor may go to the brain."

Has a pleasant, pungent, clove flavor.

Use in casseroles, stews, soups, ragouts, and with eggs, potatoes, fish, and green vegetables.

## TURMERIC

Hindus believed that it had erotic qualities and used it in wedding rites and for vigor. Garments were colored with the yellow powder. It's also believed to be mildly antiseptic.

Has an aromatic, mild flavor.

Use with eggs and in chutneys, relishes, pickles, and rice and bean dishes.

## VANILLA BEAN

The pod of a climbing orchid, vanilla grows in tropical climates and was used by the Aztecs for flavoring chocolate. Bury chunks of it in sugar for a subtle vanilla flavor.

Has a sweet, rich taste.

Use in custards, ice cream, and pastries, and to flavor sauces.

## STORING HERBS

Wrap fresh herbs in damp paper towels. Put them in a cool place where they'll keep for a few days. For longer storage, freeze or dry herbs.

## WHAT IS A BOUQUET GARNI?

It is usually bay leaves, thyme, and parsley tied together with string or wrapped in cheesecloth.

Use to flavor casseroles and soups. Remove after cooking.

## WHAT ARE FINES HERBES?

These are equal amounts of fresh parsley, tarragon, chives, and chervil chopped fine, and are commonly used in French cooking. Old farmers kept these ingredients in their kitchen garden. Collected with the morning eggs, they made a fine omelet or added zest to soups and sauces.

Put in salads, omelets, and butter sauces, or sprinkle on noodles, soups, and stews.

## WHAT IS AN HERB BOUQUET?

This is used to flavor soups, stews, and chowders as well as poached chicken and fish. Tie sprigs of fresh herbs together with twine. Or put dried herbs and spices in a four-inch square of cheesecloth and tie securely. Always remove bouquet before serving. All recipes make one bag of dried herbs.

### CHICKEN

- 1 bay leaf
- 1 tablespoon tarragon
- 1 tablespoon parsley
- 1 teaspoon rosemary
- 1 teaspoon thyme

### BEEF

- 1 teaspoon black peppercorns
- 2 whole cloves
- 1 broken bay leaf
- 2 teaspoons thyme
- 2 teaspoons marjoram
- 2 teaspoons savory
- 1 tablespoon parsley
- 1/2 teaspoon crushed lovage

### FISH

- 1 bay leaf
- 2 black peppercorns
- 1 teaspoon thyme
- 1 teaspoon fennel weed
- 1 teaspoon lovage
- 1 tablespoon parsley

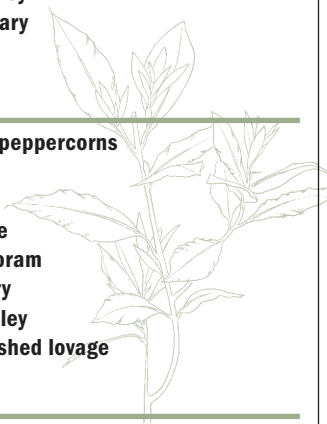

## SIMPLE CURRY POWDERS

A blend of many spices, curry powder traditionally depends heavily on coriander for tone, turmeric for color, and red pepper and chilies for heat.

Fragrant, exotic taste.

Use in curry dishes, soups, potato salads, and deviled eggs.

### NUMBER 1

- 2 tablespoons ground coriander
- 1 tablespoon chili powder
- 1 tablespoon ground cumin
- 1 teaspoon fenugreek
- 1 tablespoon ground turmeric
- 1 teaspoon ground ginger
- 1 teaspoon ground allspice
- 1 teaspoon ground black pepper

Makes about 1/2 cup. Store in an airtight jar and use as needed.

### NUMBER 2

- 4 tablespoons ground coriander
- 3 tablespoons ground turmeric
- 2 tablespoons ground cumin
- 1 tablespoon ground black pepper
- 1 tablespoon ground ginger
- 1 teaspoon ground fennel
- 1 teaspoon chili powder
- 1/2 teaspoon cayenne pepper

Makes about 1 cup. Store in an airtight jar and use as needed.

## SPICY CHICKEN RUB

- 2 teaspoons chili powder
- 1 teaspoon ground oregano
- 1 teaspoon cilantro leaves, dried and crumbled
- 1/2 to 1 teaspoon cayenne pepper
- 1 teaspoon garlic powder
- 1/2 teaspoon ground black pepper
- 1/2 teaspoon ground ginger
- 1/2 teaspoon ground cumin

Mix herbs and spices and keep in an airtight jar in a cool place. When ready to use, mix with a small amount with water to form a paste. Rub chicken pieces with some lemon juice and then the paste, cover, and let stand in the refrigerator a few hours. Sprinkle with salt and cook in oven or barbecue until chicken is done.



## SPICE MIXES FOR GOOD HOT

### CHILI

Mix the spices, store in an airtight jar, and use as needed when cooking chili.

#### NUMBER 1

- 1/4 cup paprika
- 1/4 cup chili powder
- 1 tablespoon ground cumin
- 1-1/2 teaspoons salt
- 1 teaspoon black pepper
- 1 teaspoon garlic powder
- 1/2 teaspoon cayenne pepper

#### NUMBER 2

- 1/4 cup chili powder
- 2 teaspoons ground cumin
- 1-1/2 teaspoons salt
- 1 teaspoon oregano
- 1 teaspoon garlic powder
- 1 teaspoon red pepper sauce
- 1/2 teaspoon cayenne pepper

#### NUMBER 3

- 1/4 cup chili powder
- 1 tablespoon paprika
- 1 teaspoon ground cumin
- 1 teaspoon ground cinnamon
- 1 teaspoon garlic powder
- 1 teaspoon sugar
- 1/2 teaspoon turmeric
- 1/2 teaspoon ground coriander
- 1/2 teaspoon salt
- 1/4 teaspoon ground allspice
- pinch of cayenne pepper



## PUMPKIN OR SQUASH PIE SPICE BLEND

- 1/3 cup ground cinnamon
- 1 tablespoon ground ginger
- 1 tablespoon ground nutmeg or mace
- 1-1/2 teaspoons ground cloves
- 1-1/2 teaspoons ground allspice

Mix the spices and keep handy in a jar. Next time you bake a pie, just add 1 to 1-1/2 teaspoons of the spice mix.

## BREAKFAST SPICE SHAKER

- 1 cup white sugar
- 3 tablespoons ground cinnamon
- 1 teaspoon ground nutmeg or mace
- 1 teaspoon ground cardamom

Mix the ingredients well and keep in a cool, dry place. Next time you have pancakes, toast, or oatmeal, just sprinkle the mixture on top.



# Quick Fixes for Culinary Calamities

It happens to every cook now and then: Something tastes bland, or the chicken is pink and your guests are waiting at the table. Here are some common kitchen problems (P) and their solutions (S).

## At the Last Minute, You Realize That . . .

**P The soup is sadly lacking in flavor.**

**S** Perk up bland stock with a couple of bouillon cubes dissolved first in a small amount of boiling water. Almost any good dry wine (in small quantity) will also help a soup.

**P The soup is too salty.**

**S** Add a raw potato to the soup and boil for a short time. The potato will absorb some of the salt. Remove and discard the potato.

**P The soup is too greasy.**

**S** Wrap several ice cubes in a plastic bag. Keep the bottom surface level, and move it slowly over the surface of the warm soup. The fat will harden and cling to the plastic. You may have to repeat this a few times; reuse the same ice bag by holding it under running hot water just long enough to melt the fat. Next time: Refrigerate the soup overnight. The fat will congeal on the top and can be lifted out in one piece.

**P The roast turkey or chicken you're carving is pink or raw at the bone.**

**S** Dark meat (the legs and thighs) takes longer to cook than white (breast) meat. You can remove the breast meat and serve it first. In the meantime, turn the oven to 450°F and continue roasting the legs and thighs until done, another 15 minutes or so. Or, you can microwave those pieces on high power for several minutes until they are cooked through.

**P The roast turkey or chicken is very dry.**

**S** Slice the cooked poultry and arrange it on an ovenproof platter. Make a sauce of half butter, half chicken broth, and pour it over the meat. Let it stand for 10 minutes in a 250°F oven to soak up the juices.

**P The gravy is lumpy.**

**S** To smooth lumpy homemade gravy, try blending it vigorously with a wire whisk. If there are still lumps, whirl the mixture in a blender or food processor. If necessary, reheat before serving.

**P The gravy is too salty.**

**S** Increase your quantity of gravy (thus diluting the saltiness); or add a few pinches of

brown sugar; or cut a raw potato into thin slices and cook them in the gravy until they become translucent. Remove potato.

**P The vegetables are overcooked.**

**S** Chop them up and combine them with a can of creamed soup (any kind will do!). Heat and serve.

**P You forgot to soak the beans you want to bake.**

**S** Shorten the time for cooking beans by adding 1 teaspoon of baking powder to 1 pound of beans; cover with water and cook until soft (about 40 minutes). Drain, then bake according to recipe. (Bear in mind that beans baked with tomatoes require 10 to 20 percent more cooking time.)

**P You don't have a garlic press.**

**S** Rub the peeled cloves over the small holes of a grater. Mash the fine shreds with the back of a fork and you have perfectly minced garlic. And cleanup is a breeze.

**P Your eggs crack during boiling.**

**S** To keep the whites from seeping out, add to the boiling water 1 teaspoon of salt or a few drops of lemon juice or vinegar.

**P Your pasta is stuck together.**

**S** After draining the pasta, plunge it quickly back into boiling water to which you have added a pat of butter or a tablespoon of oil. Drain; your pasta should come unstuck. (Next time, put the oil in the water before you add the uncooked pasta!)

**P The gelatin salad or dessert that you plan to serve is still soupy.**

**S** Fill a large pan with ice, sprinkle with salt, then place the dish of gelatin over it to speed up the setting process.

**P The fruit pie has a soggy bottom crust.**

**S** Serve the pie in bowls. To prevent this from happening next time, get the filling into the pie shell and in the oven quickly. If

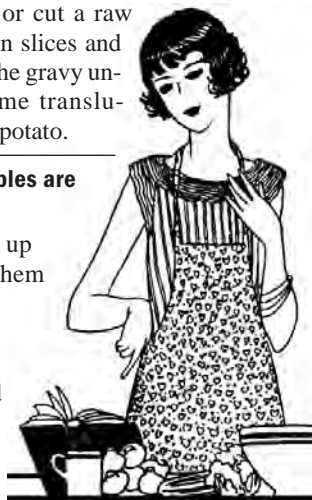

a puddle of juice forms in the bottom of the mixing bowl, don't pour it into the pie shell.

## When You've Run Out of . . .

**P Baking powder . . .**

**S** Make a baking powder substitute by mixing 2 teaspoons cream of tartar, 1 teaspoon bicarbonate of soda, and ½ teaspoon of salt. Substitute for an equal amount of baking powder, reducing any additional salt in the recipe. (The mixture is effective only for a day or so; use it right away.)

**P Superfine sugar . . .**

**S** Make your own extra-fine granulated sugar by whirling granulated sugar in a food processor until it is finely ground, about two minutes. Superfine sugar dissolves more rapidly in cold liquids than regular sugar, so it is useful in drinks such as lemonade and iced tea.

**P Sugar . . .**

**S** For 1 cup of sugar, substitute ¾ cup of honey or 1½ cups of molasses, and reduce the amount of other liquids in the recipe. If using honey, reduce liquids by one-half; if using molasses, decrease the amount of other liquid by 2½ fluid ounces for every cup of molasses and add 1 teaspoon of baking soda. Bake at a slightly lower temperature.

**P Eggs . . .**

**S** Replace 1 egg in 3 with a tablespoon of cornstarch. Also, 2 yolks will substitute for 1 entire egg. If it's egg whites you need, add 1 teaspoon cream of tartar for each cup of egg whites. This will increase their volume by allowing them to beat up fluffier.

## In the Midst of Baking, You Discover That . . .

**P The recipe calls for softened butter and yours is chilled firm.**

**S** Shred the chilled butter over the large holes of a grater and spread the shreds out on a platter or cookie sheet. They will soften quickly. Or, put the butter in the microwave for 10 to 30 seconds.

**P The brown sugar is rock hard.**

**S** Put the sugar in a plastic container and



microwave it for ½ to 1 minute. If it is still hard, add a couple of drops of water and microwave again. Or, put the sugar in a pan in a moderate preheated oven, turn off the heat, and let stand until it softens.

**P The recipe calls for eggs at room temperature and yours are refrigerator cold.**

**S** Dunk them in lukewarm water for 5 minutes. Or, ignore the recipe and use them cold.

**P The bread dough does not rise.**

**S** First, try additional gentle heat: Put a large pan of boiling-hot water in your oven, then place the bowl of dough on a rack over it and shut the door (do NOT turn on the oven). Or, if you have an electric heating pad, set it on low, cover the pad with foil, and put the bowl of dough on the foil; or put the bowl in the dishwasher and set it on the dry cycle. If gentle heat does not work: Dissolve new yeast in a few tablespoons of warm water. Pat the lifeless dough into a rectangle about ½ inch thick and sprinkle the fresh yeast mixture over it. Add a little flour to compensate for the added water, then knead the dough thoroughly to incorporate the fresh yeast. Continue with rising, forming, and baking.

■ **The next time you are kneading sticky dough when the phone rings, slip your hand into a plastic bag and use it as a mitten when you pick up the phone.**

**P You overbeat egg whites for a cake or soufflé.**

**S** For every 4 overbeaten whites, add 1 unbeaten white to the bowl, then stir or whisk gently until the beaten whites return to their proper stiff-but-not-dry stage.

**P You think that the baking powder might be too old to use.**

**S** To test baking powder for staleness, add 1 teaspoon of baking powder to 1 cup of hot water. If the mixture bubbles a lot, it's good; if it doesn't, throw it out.

**P You don't have time to chill your pie dough before you roll it out.**

**S** Unless your kitchen is exceedingly hot, chilling isn't necessary. Go ahead and roll out the freshly made dough on a generously floured surface, fit it into the pie pan, then trim and crimp the edges. Your pie won't suffer.

**P There's a bit of egg yolk in the egg whites that you separated.**

**S** Since even a tiny amount of yolk in the whites can affect their leavening ability, it is important to remove it. Moisten a cloth in

cold water and touch it to the yolk, and the yolk will cling to the cloth like a magnet.

**P You don't have enough berries for your pie.**

**S** Mix up a package of vanilla pudding and add it to the pie in layers, alternating with berries. Or, mix the pudding and berries together. Top with meringue instead of crust.

**When You Burn . . .**

**P Food during cooking . . .**

**S** Immediately remove the pan or pot from the heat and set it carefully into a sink of cold water (to stop the cooking). Spoon out all contents that will come out easily with a wooden spoon (the food that's stuck to the pan is burned—leave it alone) and transfer it to another pot. Taste the food; if it's smoky tasting, cover the pot with a damp cloth and let stand for half an hour. If it still doesn't taste right, it may be beyond repair. Now to clean the pot (other than enamel or cast iron): Fill halfway with water to which you have added a strong detergent. Boil for 10 minutes, then let stand overnight. Pour off the water; the burned part should be easily cleanable with a scouring pad or steel wool. **For enamelware:** Fill the pot with cold water to which you have added 3 tablespoons of salt. Let it sit overnight, then boil. It should clean easily. **For cast iron:** Burned food can be scoured off cast-iron pots and pans by mixing sand and vegetable oil in them

and scrubbing with steel wool. Season afterward.

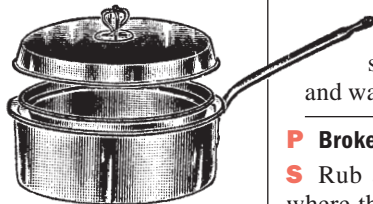

**P The bottoms of drop cookies . . .**

**S** After they have cooled, use the fine holes of a food grater to shave the burned layer from the bottoms. To keep subsequent batches from burning, either cover the cookie sheets with foil or stack two cookie sheets together, one on the other.

**P The rice . . .**

**S** Turn off the burner, take the lid off the pot, and put the heel of a loaf of bread on top of the rice. Cover the pot and wait 5 minutes—the scorched taste should be absorbed by the bread.

■ **If you're caught without a fire extinguisher when you have a grease fire, clamp a large pot lid down over the fire at once to cut off the oxygen supply, or pour baking soda on the flames.**

**To Eliminate the Odors of . . .**



**P Burned food . . .**

**S** Boil a small amount of vinegar on the stove or simmer a pot of water with a few whole cloves in it.

**P Cooked broccoli, brussels sprouts, cauliflower, or cabbage . . .**

**S** Put a piece of bread (rye seems to work best) or a slice of red pepper in the pot along with the vegetable. It should take away the odor.

**P Cooked fish . . .**

**S** Simmer a pan of water on the stove with spices such as whole cloves, cinnamon sticks, or allspice, or cut up a lemon and simmer the slices in a pan of water.

**When You Need to Clean Up . . .**

**P An egg dropped on the floor . . .**

**S** Cover the spill with lots of salt and let it stand for 20 minutes. Then wipe up.

**P Red wine spilled on your tablecloth . . .**

**S** Assure your guest you don't mind. Cover the wine spill at once with salt; rinse later in cool water.

**P Coffee spilled on your carpet . . .**

**S** Blot up the excess coffee from the carpet, then rub the stain with a solution of white vinegar, detergent, and water.

**P Broken glass . . .**

**S** Rub a damp bar of soap over the area where the glass has splintered. Then shave off the surface of the soap to which the glass has adhered. Wrap these soap peelings in newspaper and discard.

**As a Last Resort . . .**

**PHONE NUMBERS:**

Pizza Delivery

Chinese Takeout

Emergency Numbers

---



---



---



---



---



---



---



---

# 100

## UNEXPECTED USES

FOR

## EVERYDAY HOUSEHOLD ITEMS

FROM SALT, VINEGAR, AND BAKING SODA TO LEMON AND SOAP.



### SALT

- Use a pinch of salt as a toothpaste substitute.

- Rub salt on fruit stains while still wet, then put them in the wash.



- To remove mildew spots, rub in salt and some buttermilk, then let dry in the sun.

- If you spill wine or fruit juice on your tablecloth, pour salt on the spot at once to absorb the stain.

- Apply a paste of salt and olive oil to ugly heat rings on your table. Let sit for about an hour and then wipe off with a soft cloth.

- To catch a wild bird easily, sprinkle some salt on its tail.



- Sprinkle salt on a piece of paper and run your sticky iron over it a few times while the iron is hot. You should notice a big improvement next time you use the iron.

- To restore some of the color to faded fabric, soak it in a strong solution of salt and water.

- Discharge evil spells by throwing a pinch of salt over your left shoulder.

- Mix a tablespoon of salt into the water of a vase of cut flowers to keep them fresh longer.

- A mixture of salt and vinegar will clean brass.

- Salt on the fingers when cleaning meat or fish will prevent the hands from slipping.

- To kill unwanted weeds growing in your driveway or between bricks and stones, pour boiling salt water over them.

- When moving into a new house, bring some salt to ensure happiness and peace.

- To treat perspiration stains, add enough water to salt to make a paste, then rub into the cloth. Wait for an hour, then launder as usual.

- Cover spilled eggs with salt, then wipe clean with a paper towel.

- To freshen smelly sneakers (or any canvas shoe), sprinkle their insides with salt. Wait 24 hours for the salt to absorb the odor; shake out the sneakers.

- Pour salt directly onto a grease spill and come back to it later.

- A new broom will last longer if you soak the bristles in hot salt water before using it for the first time.

- Stainless steel can be cleaned by rubbing it with a gritty paste of two tablespoons of salt mixed with lemon juice. Rinse well and pat dry with a soft cloth.

- Rub two to three tablespoons of salt onto the stains inside your glass vases, then scrub clean with a damp bristle brush.

- Gargle with warm salt water (1/4 teaspoon salt to one cup water) to relieve a sore throat.

### WHITE VINEGAR

- Bring a solution of one cup vinegar and four tablespoons baking soda to a boil in teapots and coffeepots to rid them of mineral deposits.

- A solution of vinegar and baking soda will easily remove cooking oil from your stovetop.

- Clean the filter on your humidifier by removing it and soaking it in a pan of vinegar until all the sediment is off.

- Vinegar naturally breaks down uric acid and soapy residue, leaving baby clothes and diapers soft and fresh. Add a cup of vinegar to each load during the rinse cycle.

- Saturate a cloth with vinegar and sprinkle with baking soda, then use it to clean fiberglass tubs and showers. Rinse well and rub dry for a spotless shine.

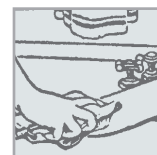

- To remove chewing gum, rub it with full-strength vinegar.

■ For a clean oven, combine vinegar and baking soda, then scrub.

■ **Clean and deodorize your toilet bowl by pouring undiluted vinegar into it. Let stand for five minutes, then flush. Spray stubborn stains with white vinegar, then scrub vigorously.**

■ Clean windows with a cloth dipped in a solution of one part vinegar and ten parts warm water. This works for dirty TV screens, too!

■ **For brunettes, rinsing hair with vinegar after a shampoo makes the hair shine. (Use one tablespoon vinegar to one cup warm water.)**



■ Soak paint-stained clothing in hot vinegar to remove the stains.

■ **To clean a drip coffeemaker, fill the reservoir with vinegar and run it through a brewing cycle. Rinse thoroughly by brewing two cycles with water before using.**

■ To remove smoke odors from clothes, hang them above a steaming bathtub filled with hot water and a cup of vinegar.



■ **Rid your refrigerator and freezer of bad odors by cleaning the insides with a solution of equal parts vinegar and water, then wiping dry.**

■ Apply full-strength vinegar to mosquito or other insect bites to relieve the itching. (Caution: Do not do this if the affected area is raw.)



■ **Vinegar takes salt and water stains off leather boots and shoes. Wipe over the stained area only, then polish.**

## BAKING SODA

■ Add baking soda to your bathwater to relieve sunburned or itchy skin.

■ **Make a paste of baking soda and water, and apply to a burn or an insect bite for relief.**

■ Clean your refrigerator with a solu-

tion of one teaspoon baking soda to one quart of warm water.

■ **Pour a cup of baking soda into the opening of your clogged drain and then add a cup of hot vinegar. After a few minutes, flush the drain with a quart of boiling water.**

■ To remove perspiration stains, make a thick paste of baking soda and water. Rub paste into the stain, let sit for an hour, then launder as usual.



■ **If you crave sweets, rinse your mouth with one teaspoon baking soda dissolved in a glass of warm water. Don't swallow the mixture; spit it out. Your craving should disappear at once.**

■ Dog odor can be eliminated by sprinkling baking soda on the dog's coat, working it into the fur with your hands, then brushing well. The odorous dirt will come out with the baking soda.



■ **Add a pinch of baking soda to boiled syrup to prevent it from crystallizing.**

■ Tough meat can be tenderized by rubbing it with baking soda. Let stand for several hours before rinsing and cooking.

■ **To remove pesticides, dirt, and wax from fresh fruits and vegetables, wash them in a large bowl of cool water to which you've added two to three tablespoons of baking soda.**

■ A pinch of baking soda added to baked beans will minimize gassy side effects.

■ **Soak toothbrushes in baking soda and warm water overnight to clean bristles.**



■ Gas and oil odors can be removed from clothes by dusting them with baking soda and letting them sit in a trash bag for a few days.

■ **Lay down a barrier of baking soda under sink-pipe openings and along basement windows to keep carpenter ants, sil-**

**verfish, and roaches from invading. Roaches eat the baking soda, dehydrate, and then die.**

■ A light baking soda paste on a damp cloth will remove bugs and tar from cars without damaging the paint. Let paste sit for a few minutes before wiping and rinsing clean.



■ **Rid plastic high chairs of spaghetti, ketchup, or crayon stains by sprinkling the tray with baking soda. Rub with a damp cloth, then rinse clean.**

■ To remove stains from your coffee and tea cups, wipe them with a damp sponge dipped in a baking soda paste.

■ **Keep your rubber gloves dry and smelling good by sprinkling baking soda inside them. They'll slip on more easily, too!**

■ Sprinkling baking soda on your front steps will provide traction and melt the ice. Unlike rock salt, kitty litter, or sand, it won't damage outdoor or indoor surfaces or shoes.

■ **Boil two inches of water in a pan with a burned bottom, turn off the heat, then add a half cup of baking soda. Let it sit overnight. In the morning, it will be easy to clean.**

■ Sprinkle a teaspoon of baking soda on the bottom of your toaster oven to eliminate the burned smell from drippings and crumbs.

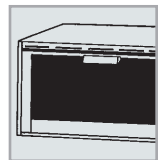

## LEMON

■ **A teaspoon of lemon juice added to boiling rice is said to make it white and keep the kernels separated.**

■ Suck on a lemon to settle an upset stomach.

■ **For a sore throat or bad breath, gargle with some lemon juice.**



■ Clean discolored utensils with a cloth dipped in lemon juice. Rinse with warm water.

■ **Toss used lemon pieces into your garbage disposal to help keep it clean and fresh-smelling.**

■ Use one part lemon juice and two parts salt to scour chinaware to its original luster.

■ **A few drops of lemon juice in outdoor housepaint will keep insects away while you are painting and until paint dries.**

■ Remove scratches on furniture by mixing equal parts of lemon juice and salad oil and rubbing it on the scratches with a soft cloth.

■ **To make furniture polish, mix one part lemon juice and two parts olive oil.**

■ Ink stains can be removed by soaking them in lemon juice.

■ **To clean the surface of white marble or ivory (such as piano keys), rub with half a lemon or use a lemon juice and salt paste. Wipe with a clean, wet cloth.**



■ To renew hardened paintbrushes, dip into boiling lemon juice. Lower heat and leave brush for 15 minutes, then wash in soapy water.

■ **To remove dried paint from glass, apply hot lemon juice with a soft cloth. Leave until nearly dry, then wipe off.**

■ Rub kitchen and bathroom faucets with lemon peel. Wash and dry with a soft cloth to shine and remove spots.

■ **Fresh lemon juice in rinse water removes soap film from the interiors of ovens and refrigerators.**

■ Create your own air freshener: Slice some lemons, cover with water, and let simmer in a pot for about an hour. (This will clean your aluminum pots, too!)

■ **Fish or onion odor on your hands can be removed by rubbing them with fresh lemon.**



■ To get odors out of wooden rolling pins, bowls, or cutting boards, rub with a piece of lemon. Don't rinse: The wood will absorb the lemon juice.

■ **Save lemon rinds to deter squirrels and cats from digging in the garden. Store rinds in the freezer during the winter, then bury them here and there just under the surface of the garden periodically throughout the spring and summer.**

■ After a shampoo, rinse your hair with lemon juice to make it shine. (Mix the strained juice of a lemon in an eight-ounce glass of warm water.)



■ **Mix one tablespoon of lemon juice with two tablespoons of salt to make a rust-removing scrub.**

■ Before you start to vacuum, put a few drops of lemon juice in the dust bag. It will make the house smell fresh.

■ **Get grimy white cotton socks white again by boiling them in water with a slice of lemon.**



■ Clean copper pots by cutting a lemon in half and rubbing the cut side with salt until the salt sticks. Rub the lemon onto the metal, rinse in hot water, and polish dry.

## SOAP

■ **To recover fine beads scattered from a broken strand, run a bar of moistened soap along the floor to locate and gather them. Wipe dry so that you don't slip.**

■ A drawer will slide more smoothly and quietly if you rub both sides and the underside with a bar of soap.

■ **To lubricate a stubborn zipper, rub soap on both sides while closed; then unzip it and rub soap over the opened teeth.**

■ Protect windowpanes, doorknobs, hardware, glass doors, and switch plates when painting by coating them with soapsuds. Paint spatters will settle on the suds, and both can be washed away together.



■ **A squeaky hinge gets the soap!**

**Wedge moist soap between the doorframe and hinge, and work the door back and forth; also rub soap directly onto the hinge.**

■ Place unwrapped soap in drawers, closets, and empty suitcases to prevent musty odors.

■ **To make a saw slide more smoothly and easily, coat both sides with bar soap. The cutting edge will go through any wood much faster.**



■ To halt squeaks in floorboards, work a little moist soap into the cracks between the boards.

■ **Loosen a tight ring by rubbing liquid soap over the finger. The ring will slide off when the hand is washed.**

■ To pick up bits and pieces of broken glass safely, rub a damp bar of soap over the area where glass has splintered, then shave off the surface of the soap to which the glass has adhered. Wrap these soap "peelings" in newspaper and discard.

■ **Prevent a watering can from dripping by rubbing moistened bar soap under the lip or spout.**



■ To loosen a stiff door lock, lubricate the key by rubbing it with bar soap.

■ **Rub sled runners generously with bar soap for a slicker ride.**

■ Pins and needles will go through material more easily if you first stick them in a bar of soap.

■ **To prepare paper logs for a cozy fire, roll old newspapers tightly into small logs, tie firmly, and soak them in soapy water. Stand them on end to drain and dry.**

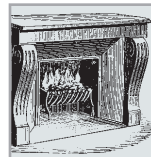

■ Planning to cook outdoors? First coat the bottom surfaces of pots and pans with bar soap; soot will wash off with the soap afterward.

■ **To keep eyeglasses from steaming in cold weather, rub both sides of each lens with soapy fingers and then polish.**